

Les techniques de dessin

Les techniques de
chiffres, de lettres,
des figures
géométriques et
autres

Le chiffre deux (2) : le canard (vu de profil gauche) qui nage.

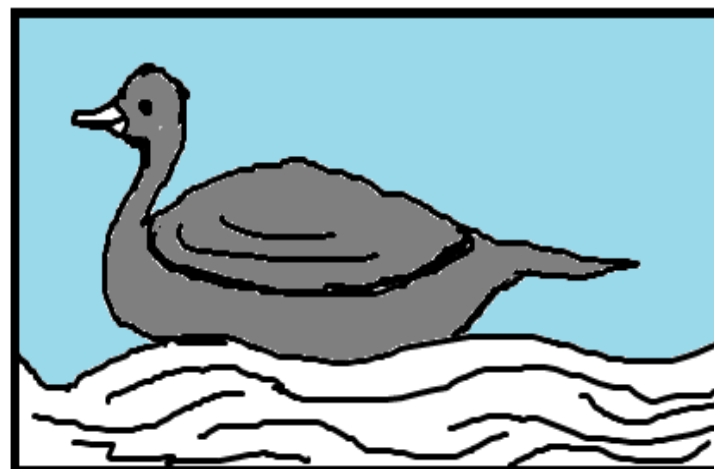

Le chiffre six (6) : la houe

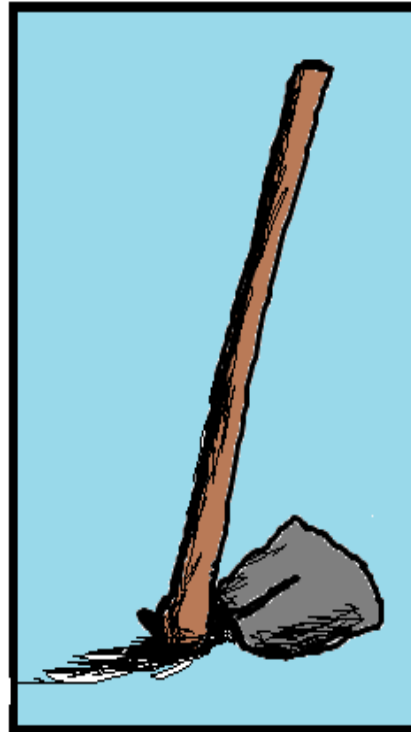
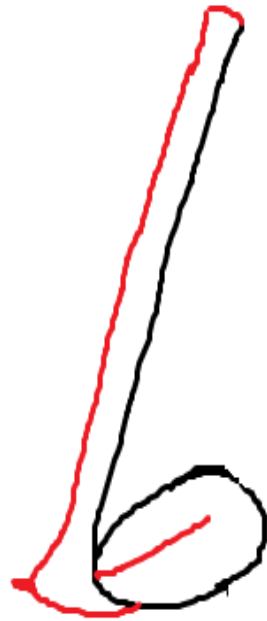

Le chiffre six: La daba

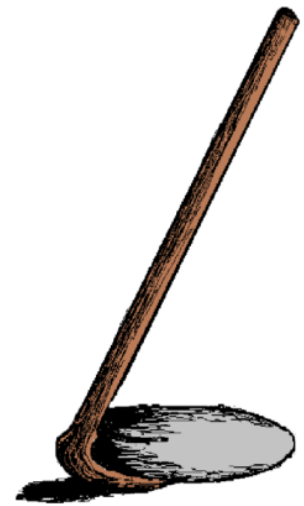
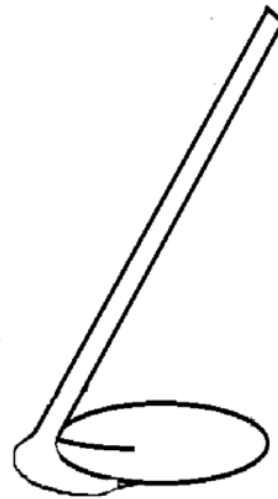
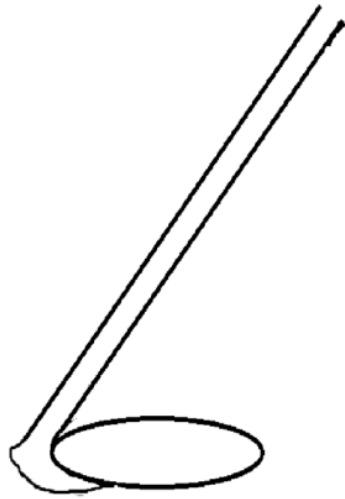
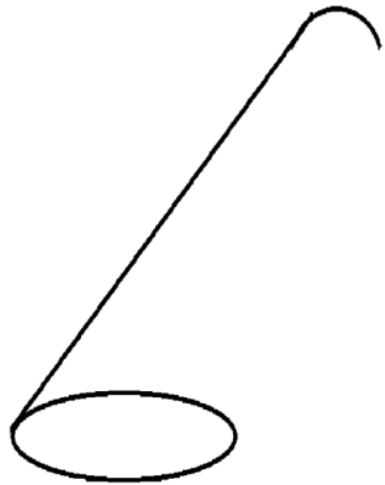

Le chiffre six(6) : le lapin assis (profil droit)



Le chiffre quatre (4) : le panneau

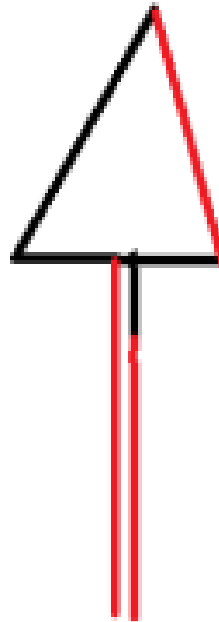
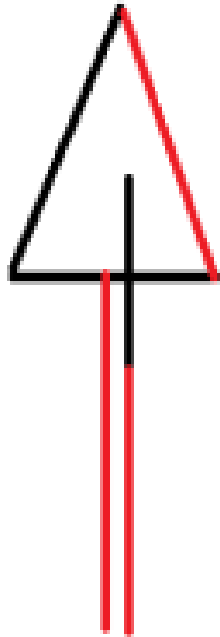
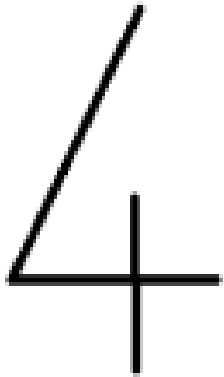

Le chiffre sept (7) : la hache

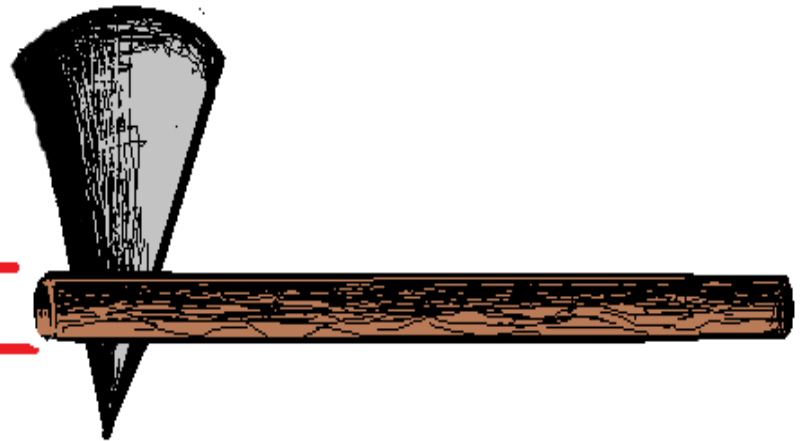
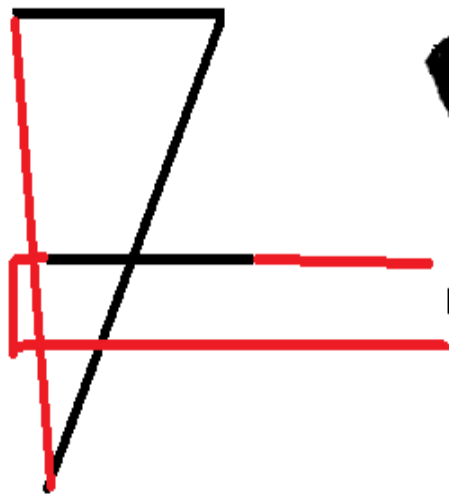
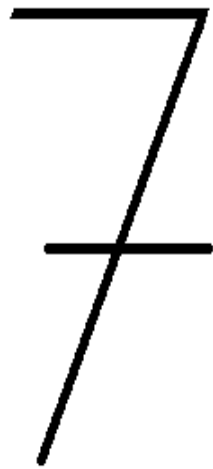

Le chiffre huit(8) : la gourde

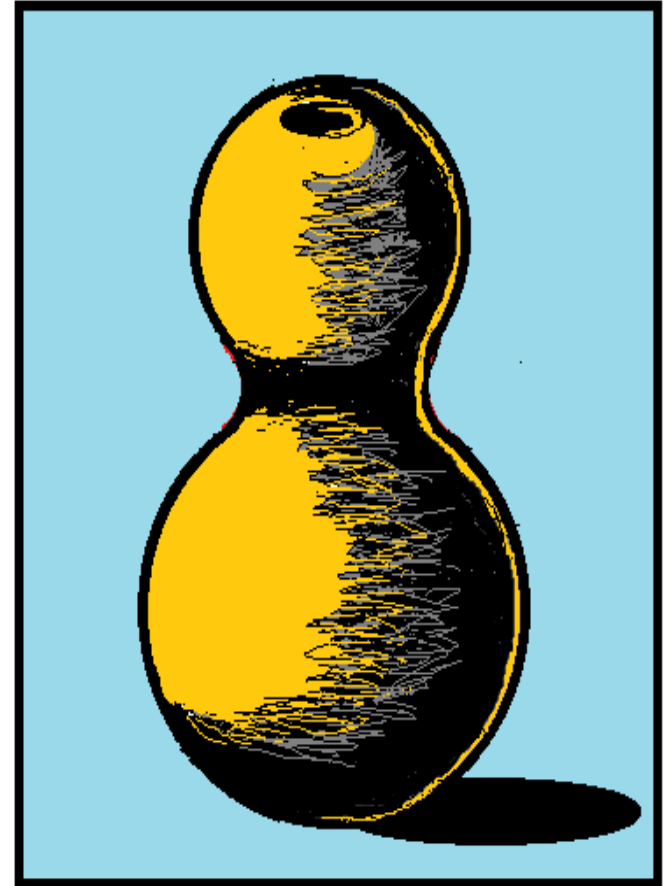
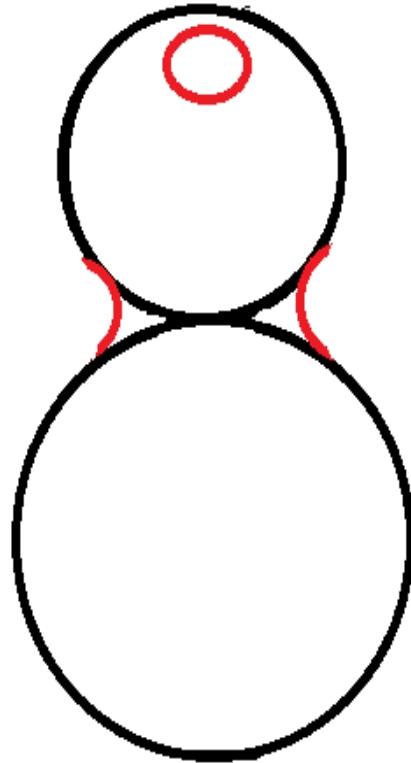
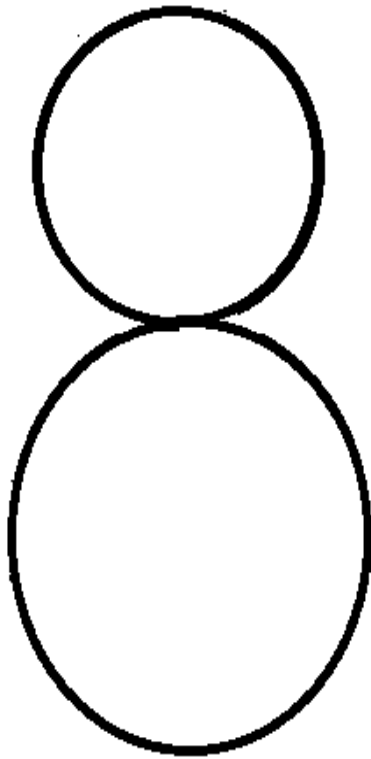

Le chiffre neuf (9) : la mangue

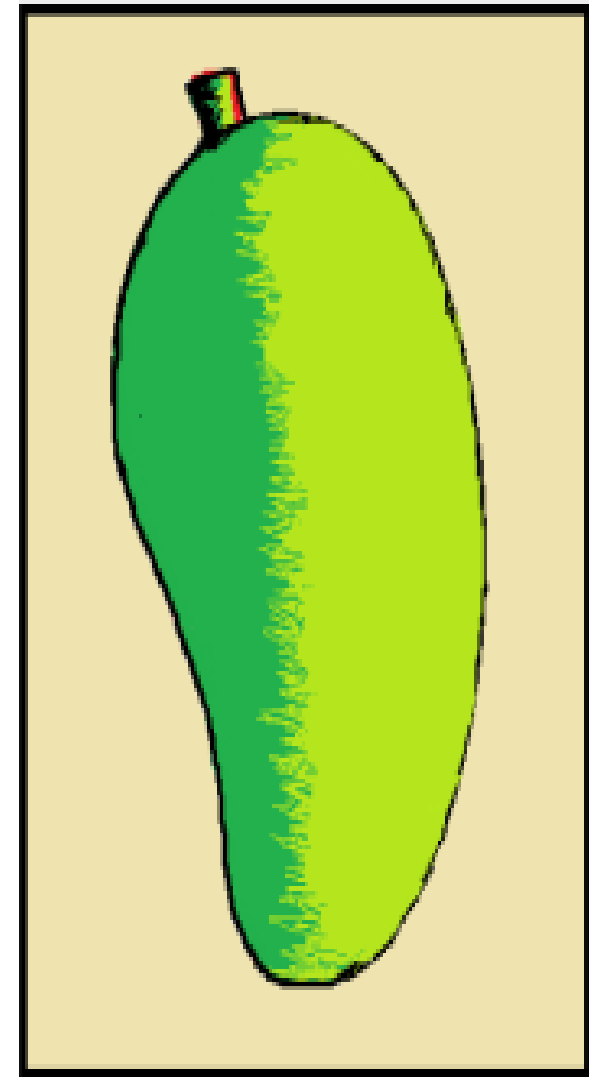
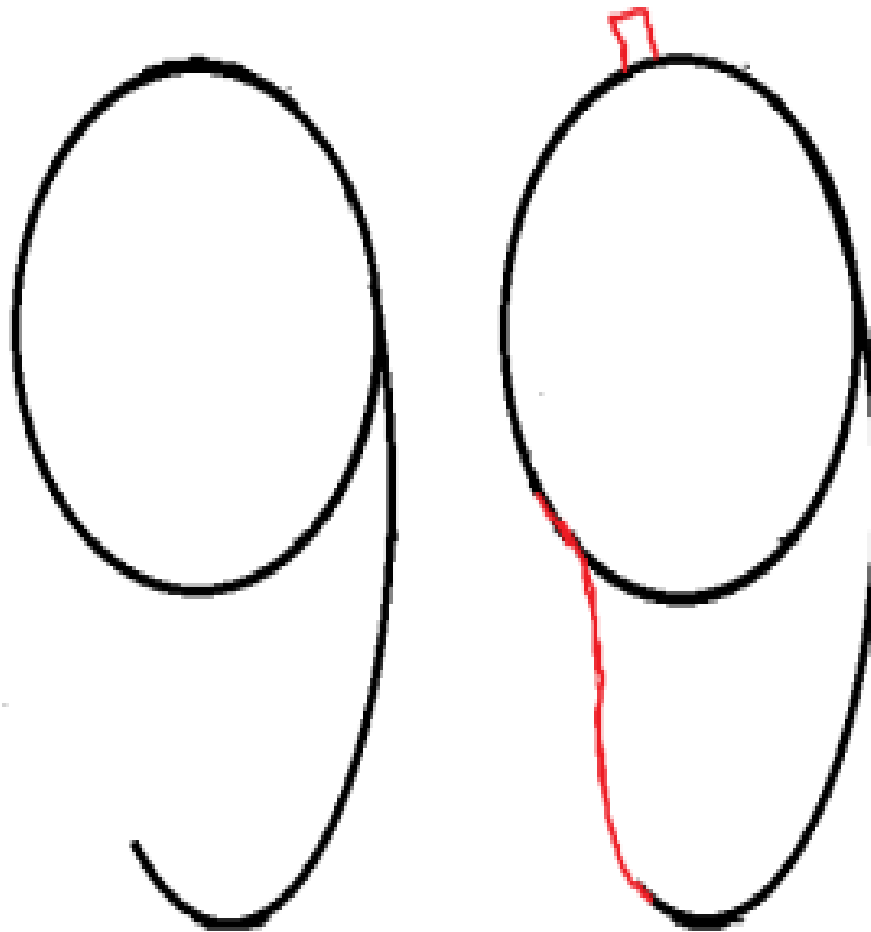

Le chiffre neuf(9) : le gobelet

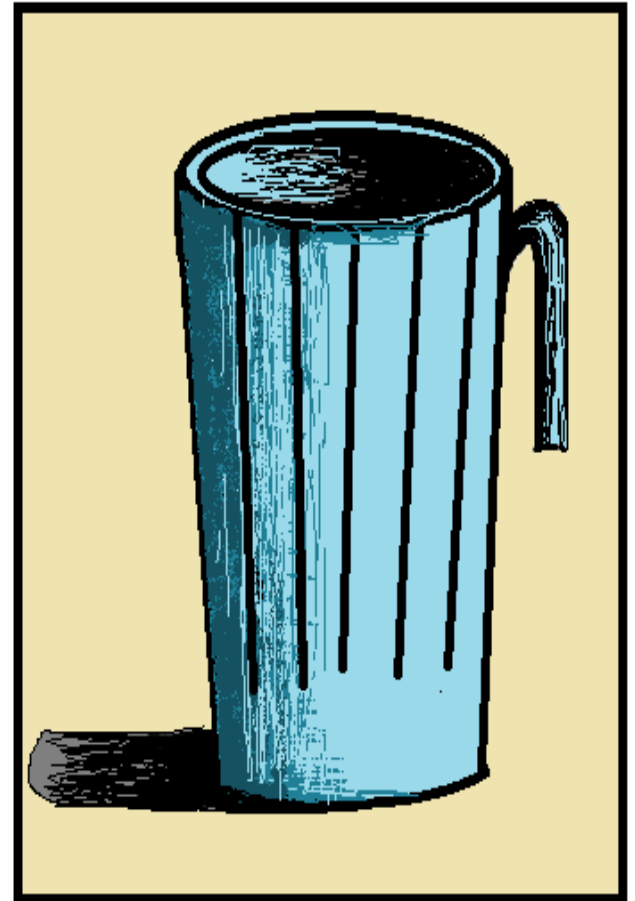
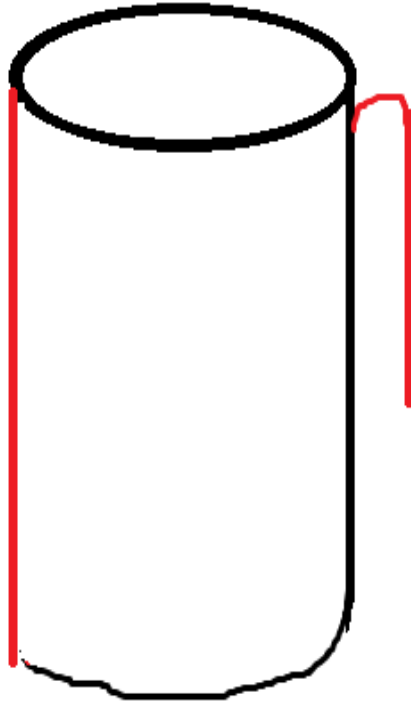
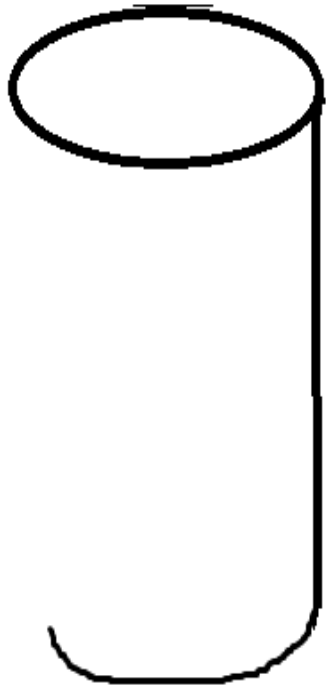

Le point d'interrogation (?), les parenthèses (), la lettre V, le chiffre quatre (4) et la barre : l'oiseau perché en face.

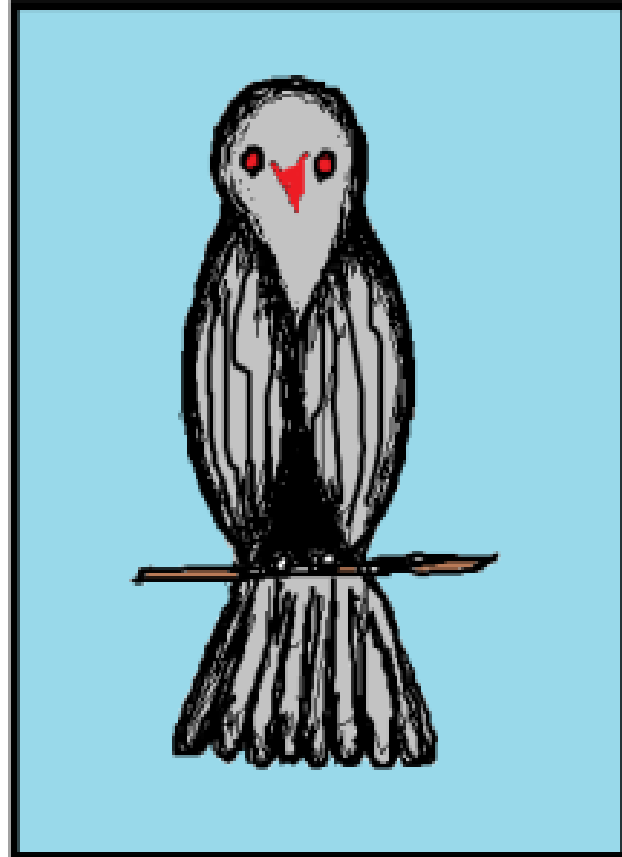
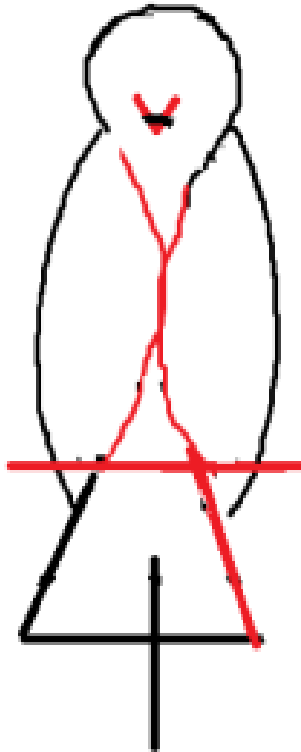
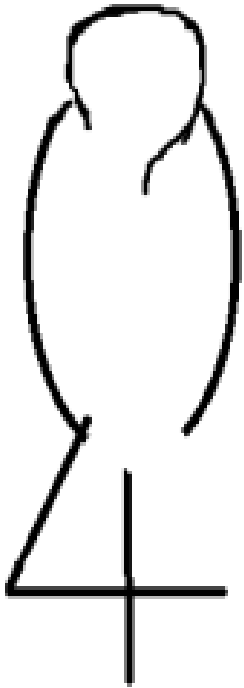

Les lettres J, O et H : l'éléphant vu de profil gauche

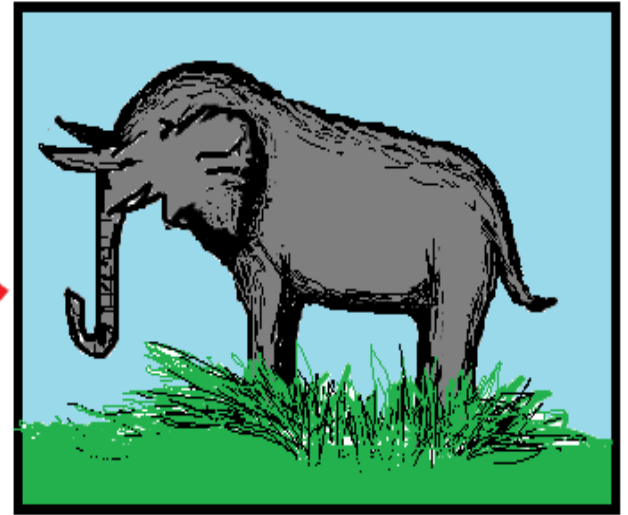
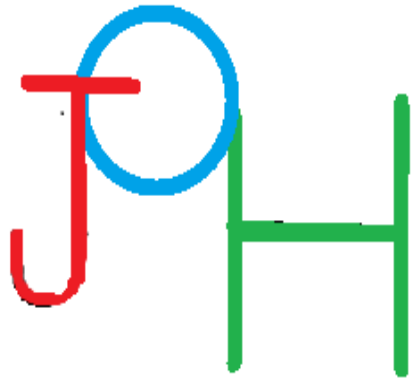

La lettre *l* : l'oiseau (vu de profil droit) perché sur une branche

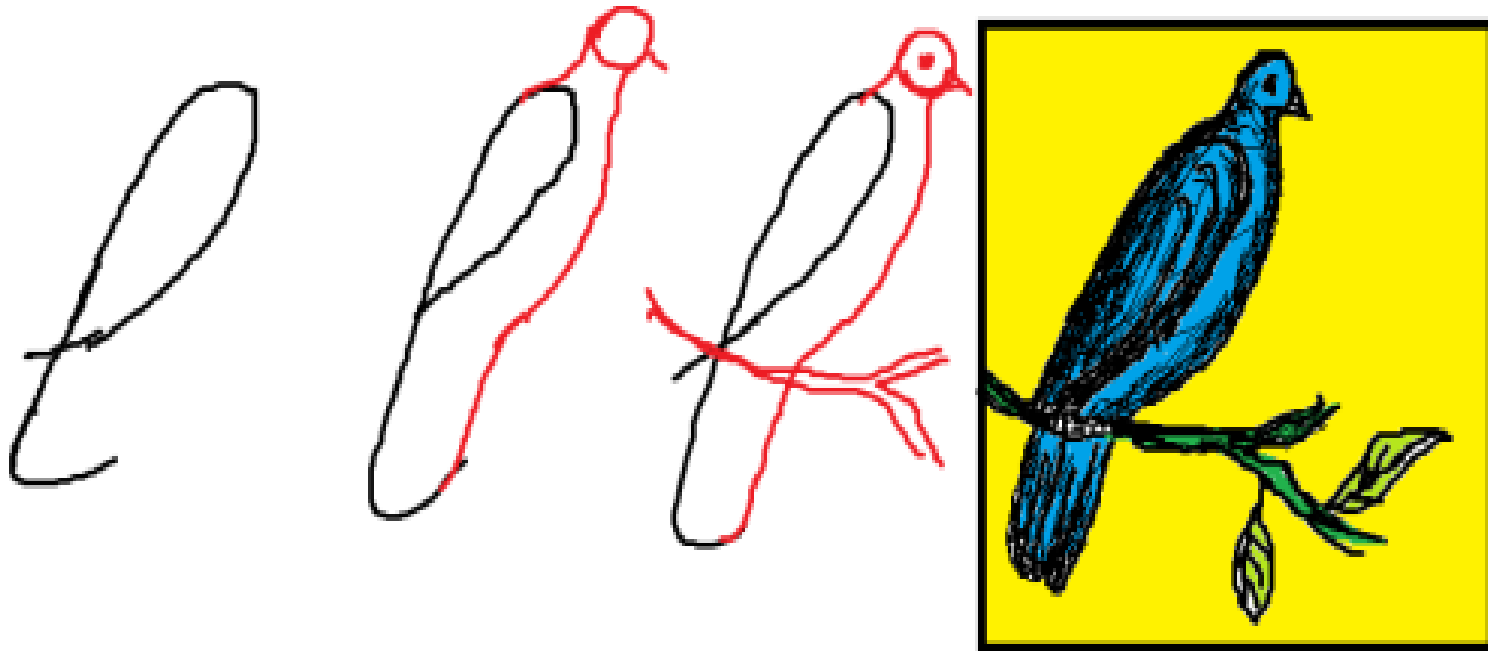

Un jeune homme

1
2
3
4

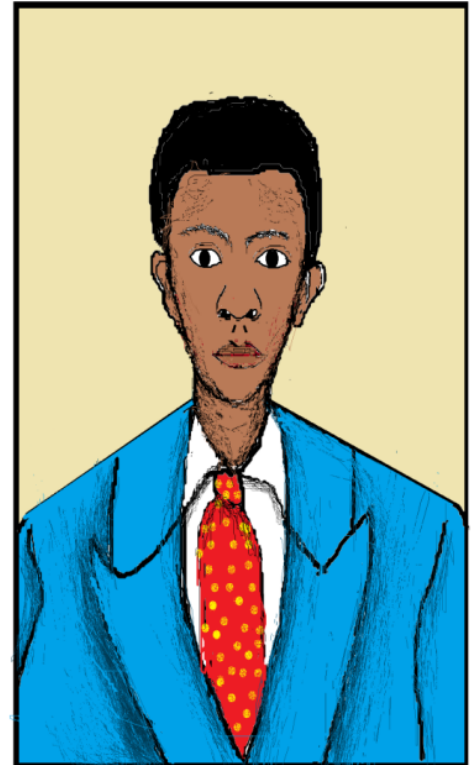
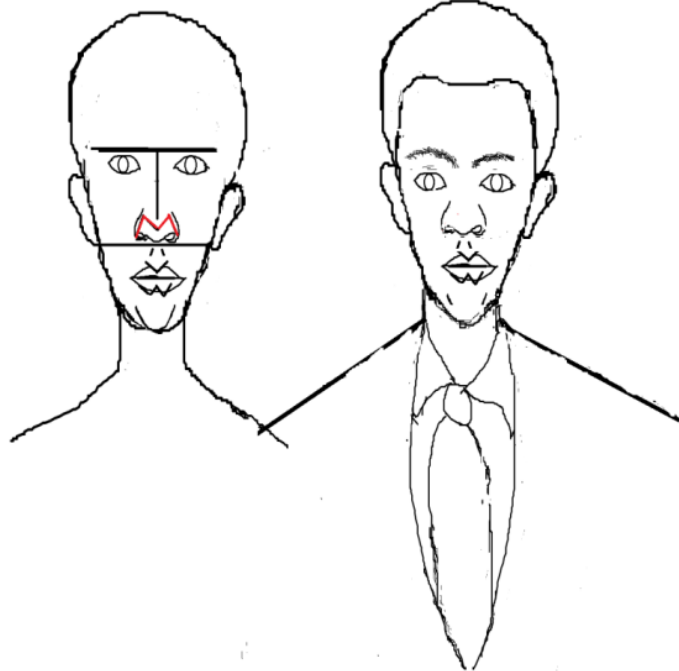
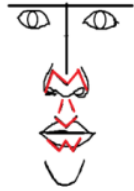

Les lettres M², W² et e : le porc vu de profil gauche

M
Σ
W W e

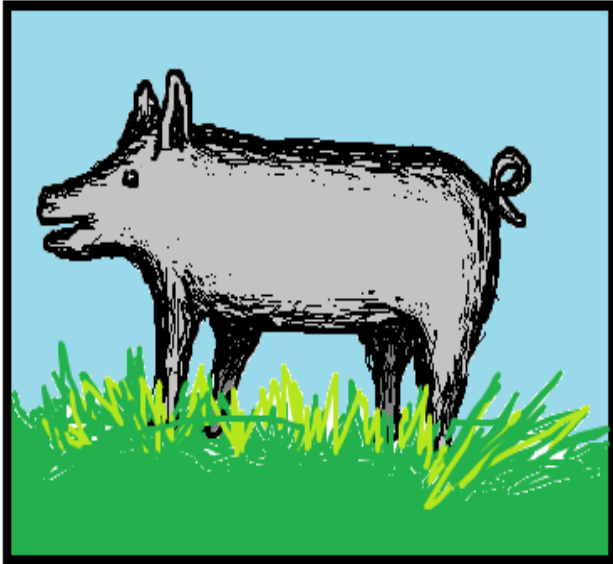
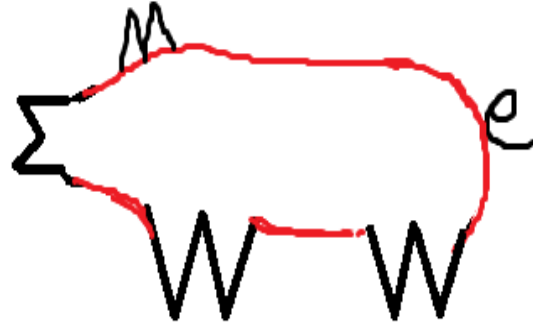

Le vélo ou la bicyclette

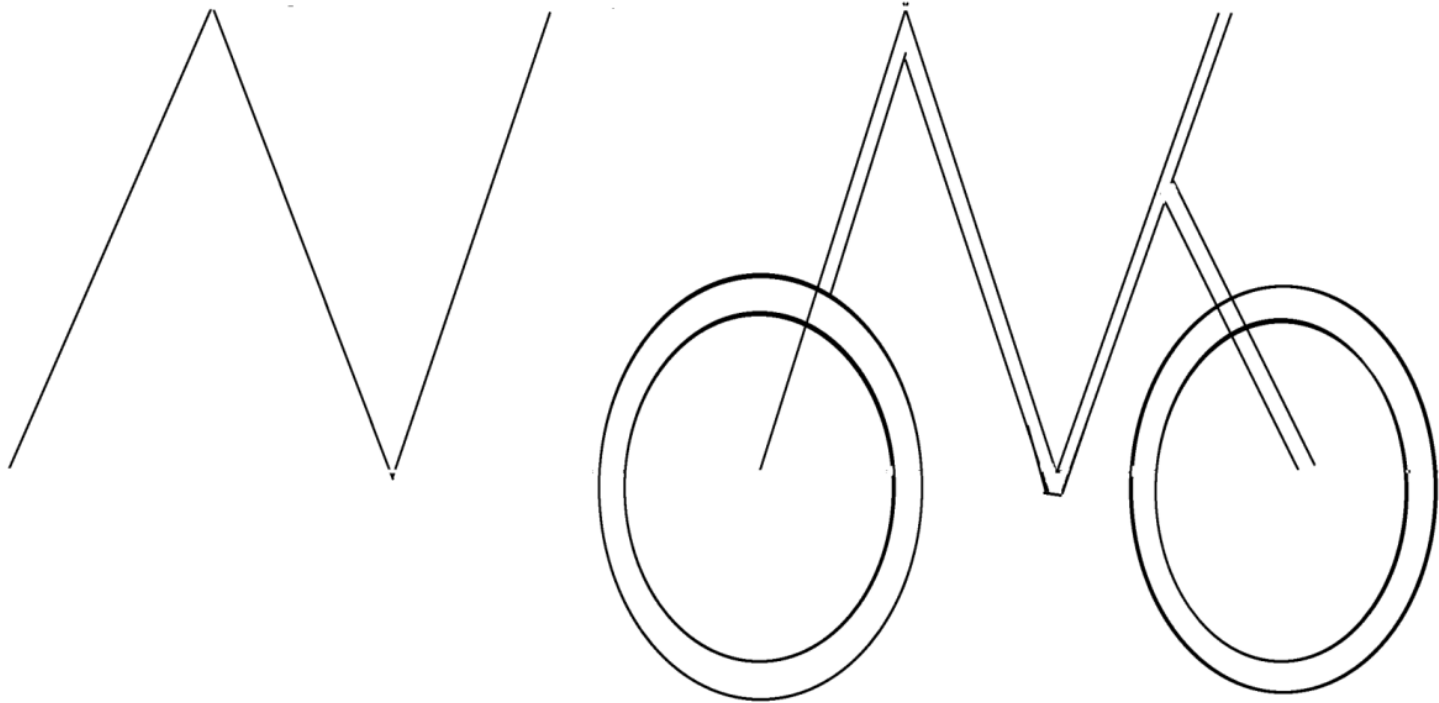

Le vélo ou la bicyclette

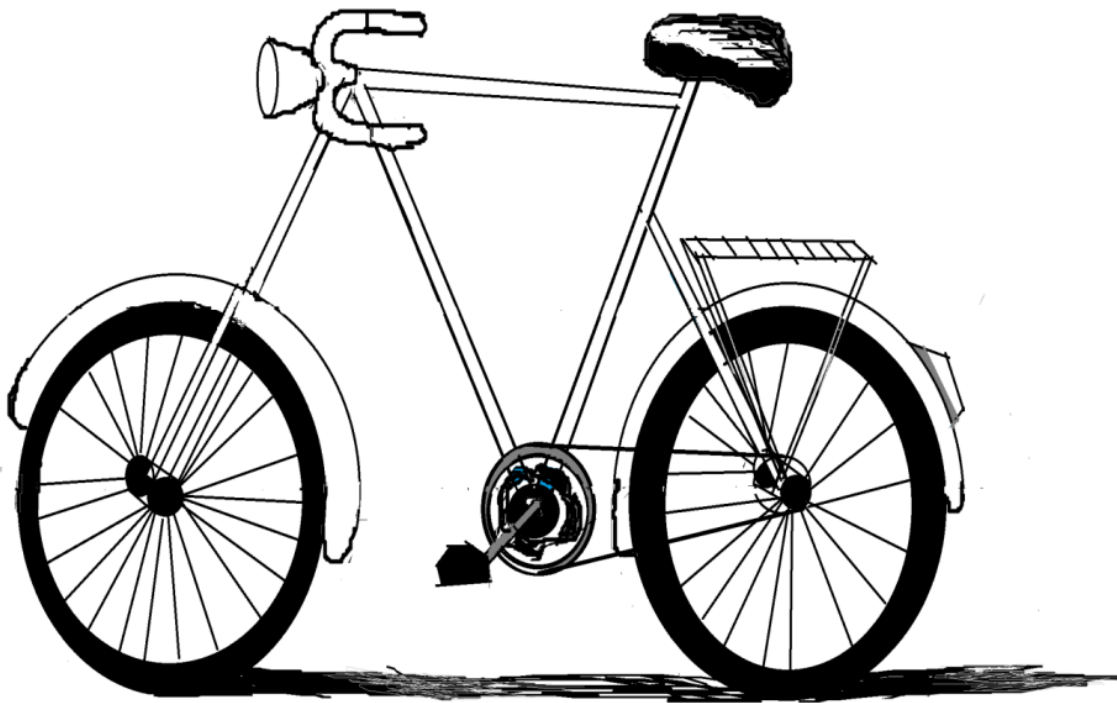

Le vélo ou la bicyclette

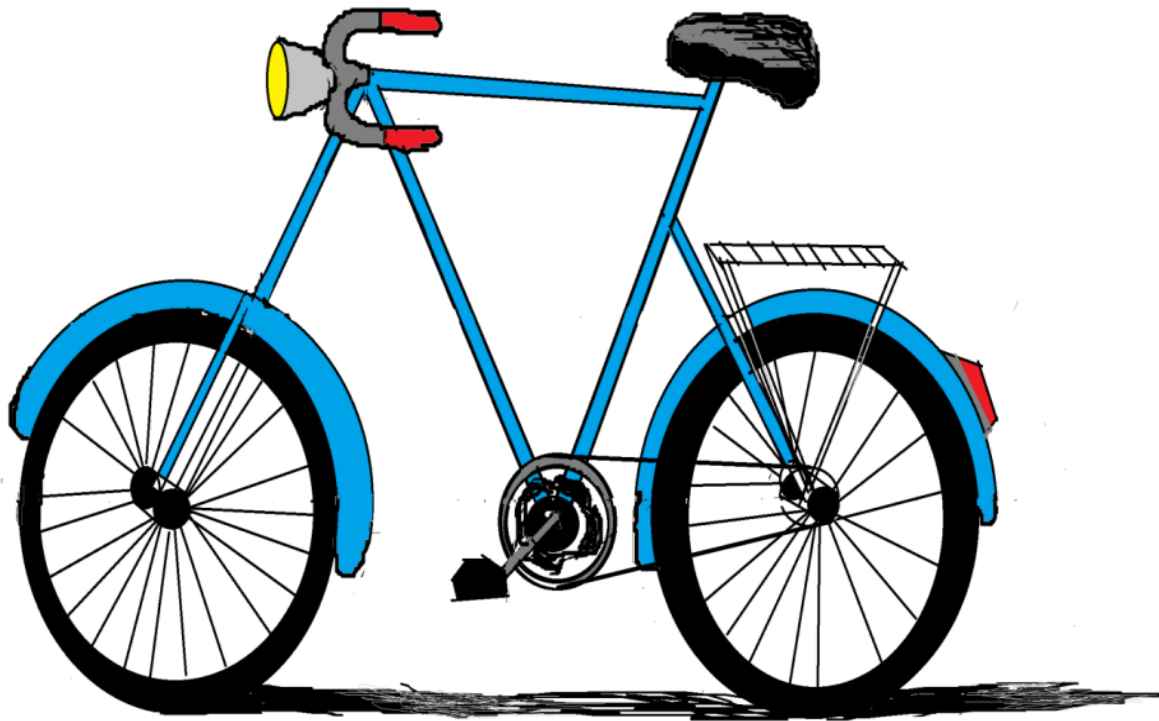

Le chat assis

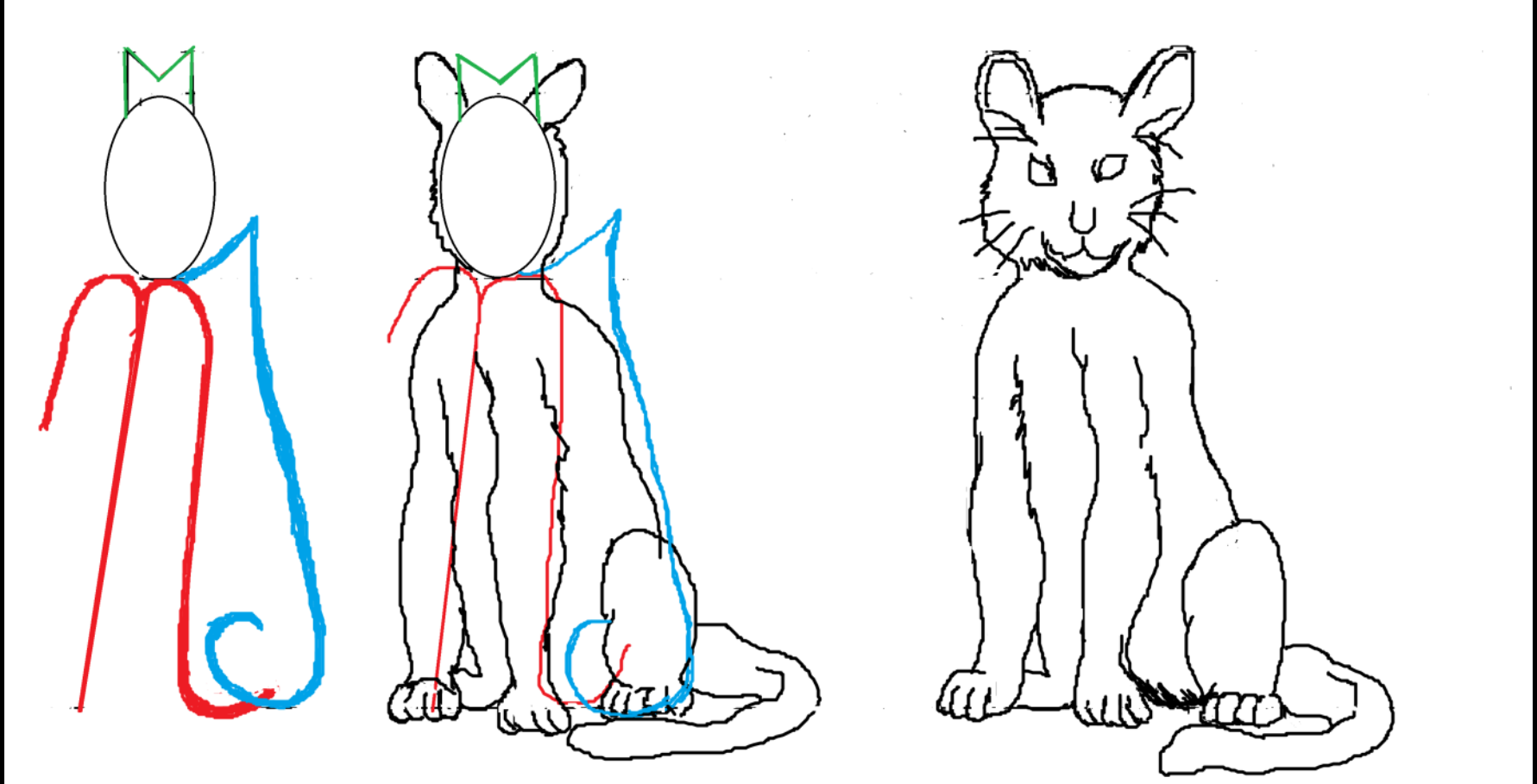

Les lettres A, O et Y: Le cultivateur

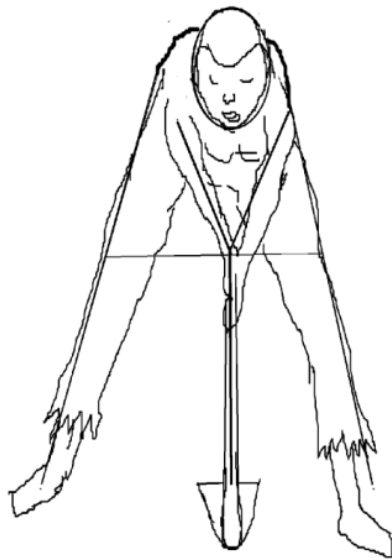
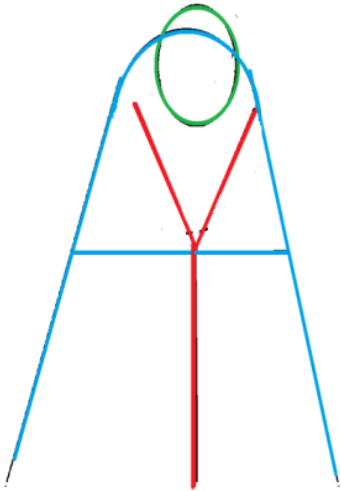

Le chat assis

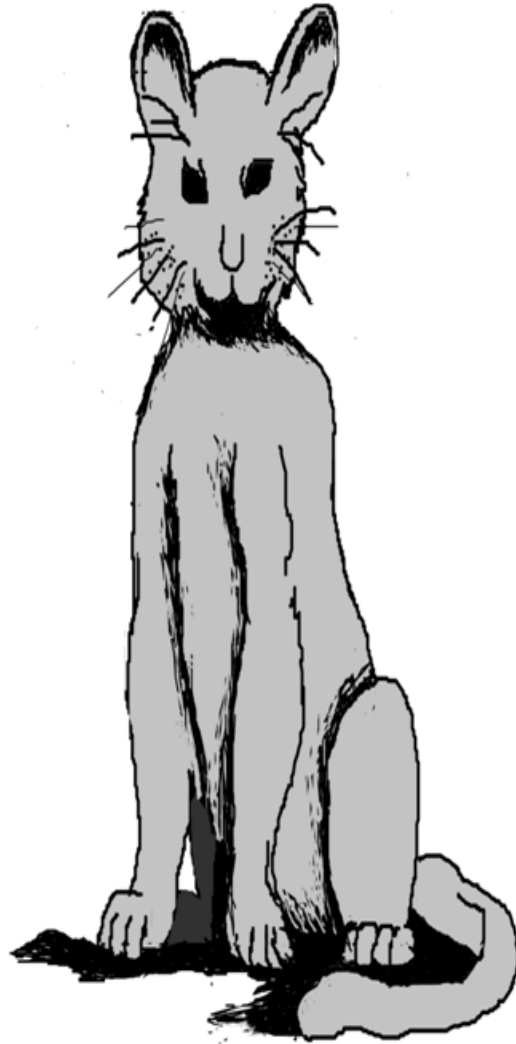

La lettre O , le chiffre 8 et le chiffre 3: Une jeune fille vue de dos

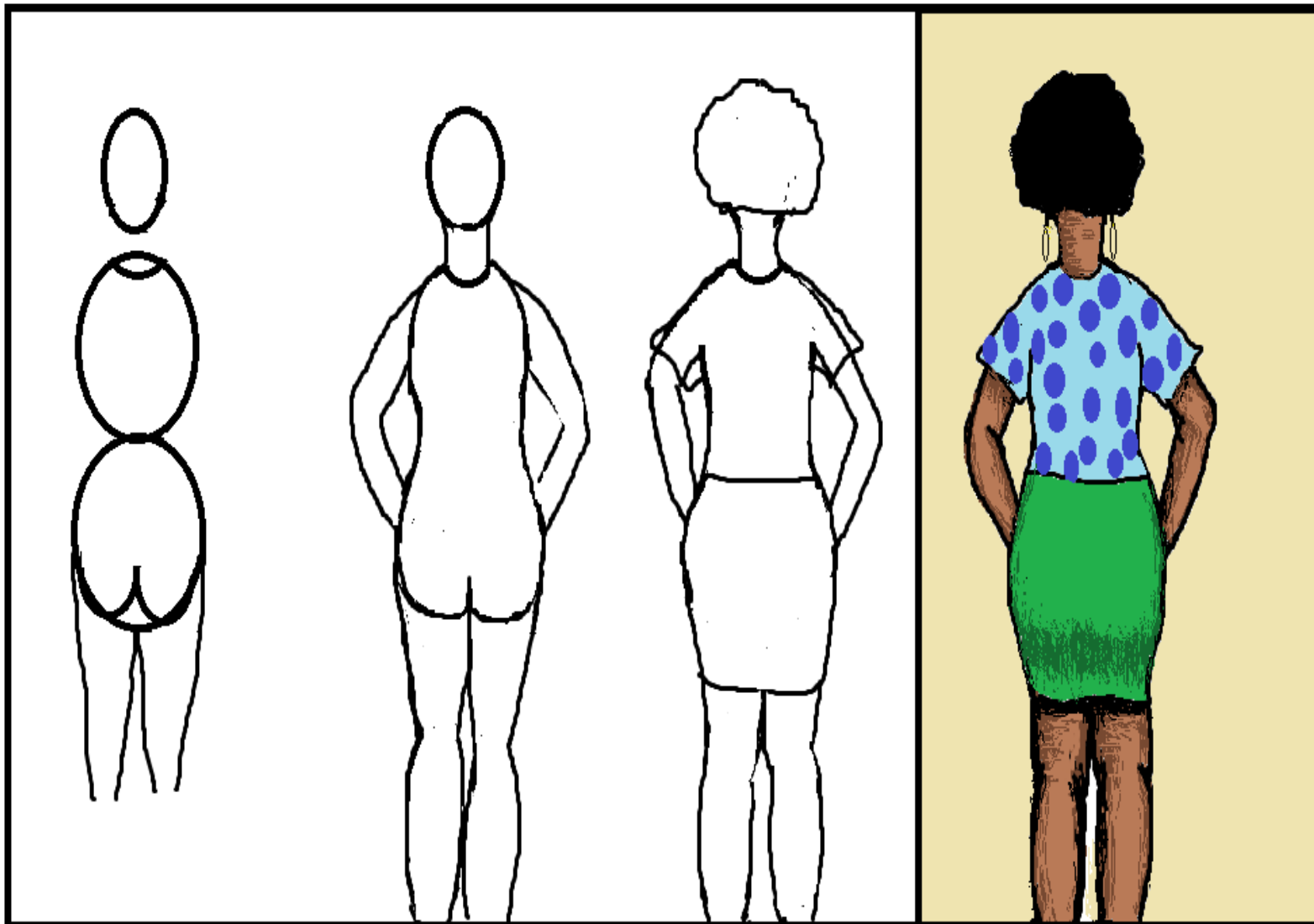

Le point d'interrogation (?), le chiffre quatre(4), le chiffre trois (3) à l'envers ou epsilon : le buste de l'homme vu de profil gauche

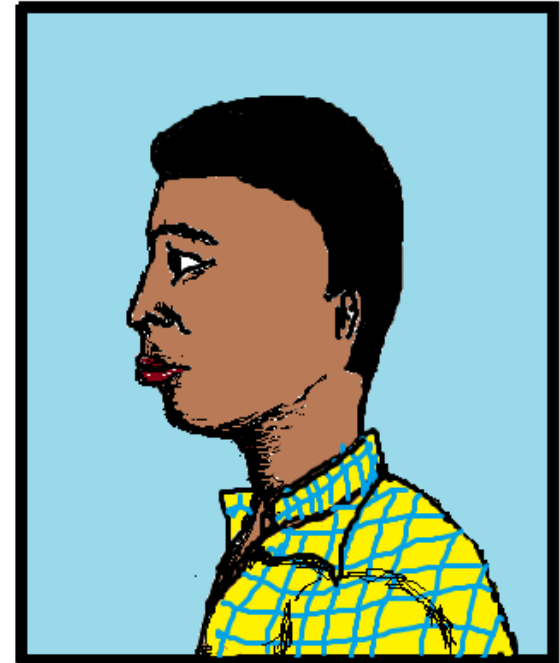

Le point d'interrogation (?), le chiffre quatre(4), le chiffre trois (3) à l'envers : le buste de la femme vu de profil gauche

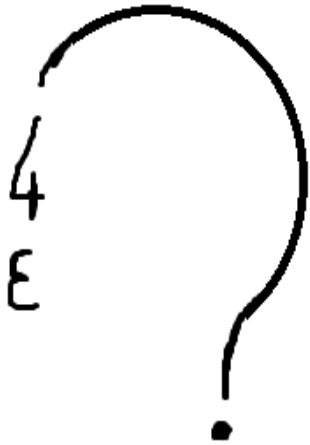

Les lettres O , le chiffre 8 et le chiffre 3: L'homme nu vu de dos

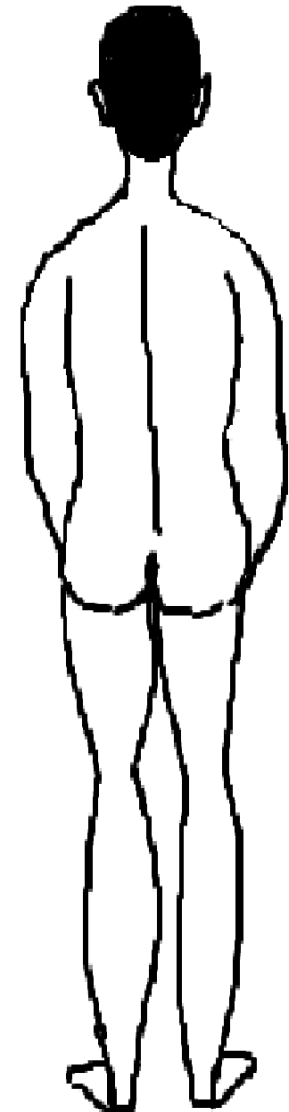
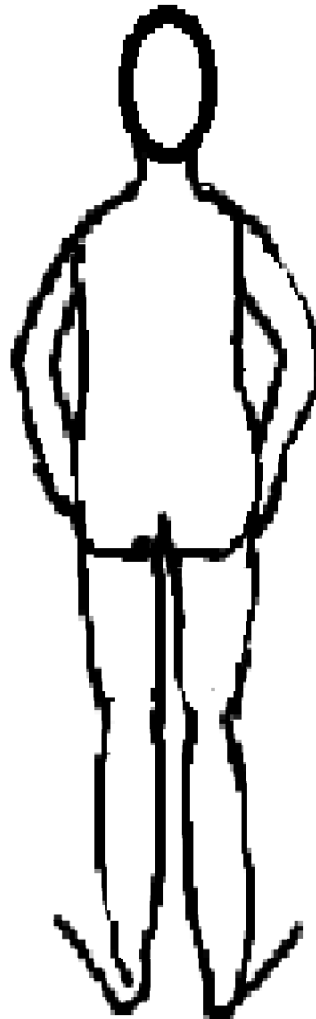

La technique des figures géométriques ou dessin géométrique

Les formes cubiques

-Le foyer métallique

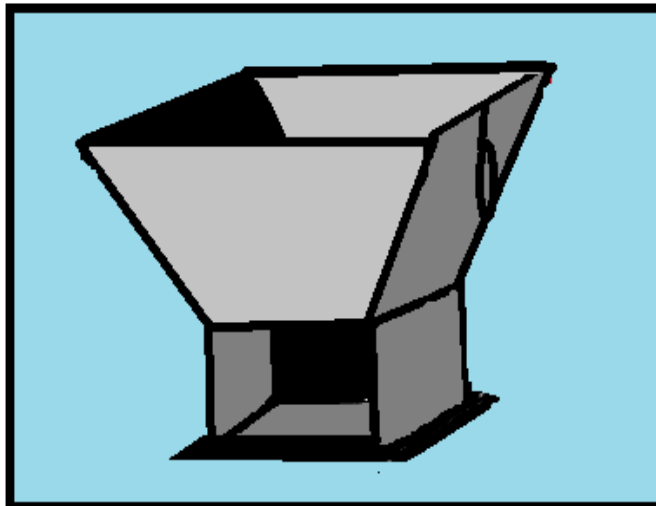
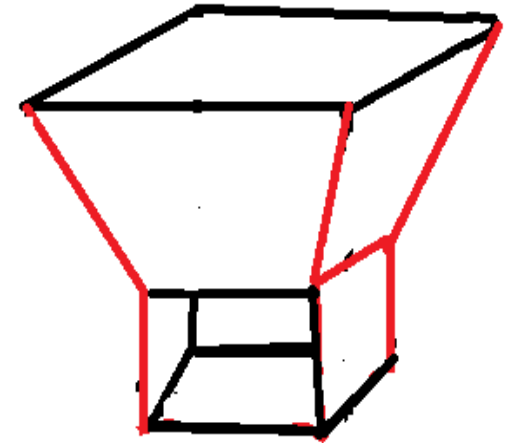
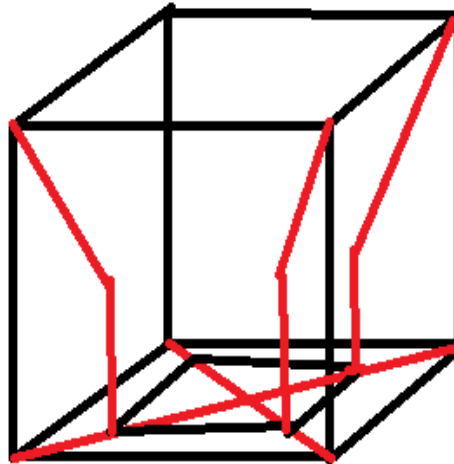
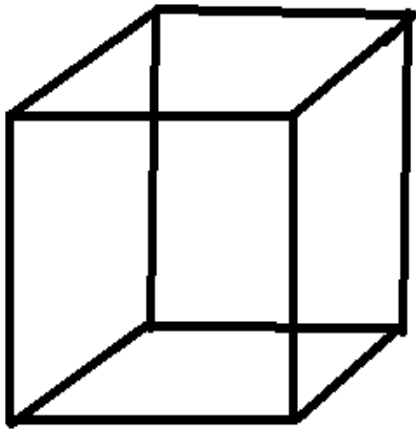

Une boîte de craies ouverte et vide

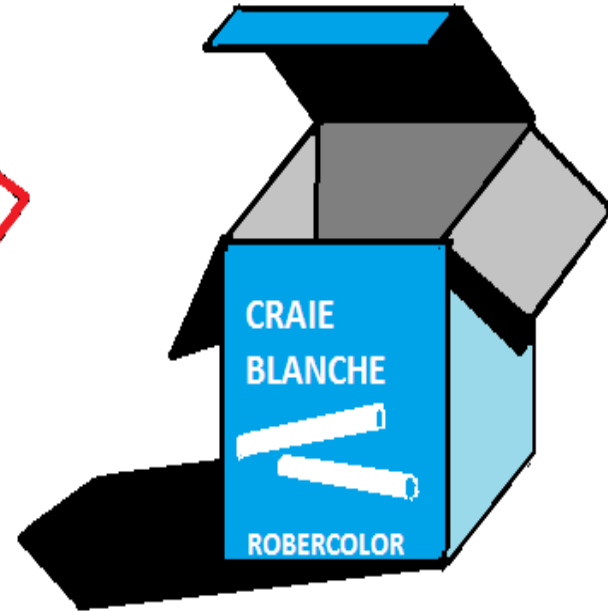
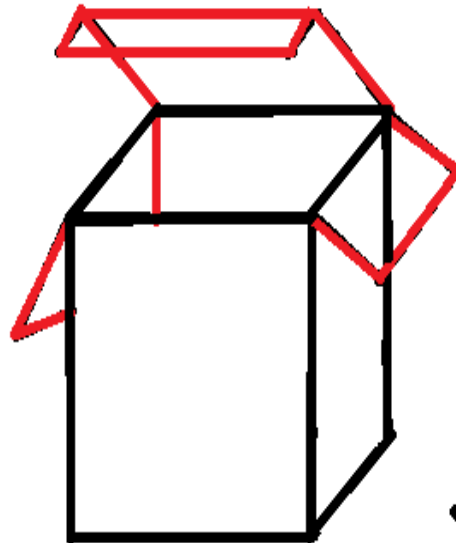
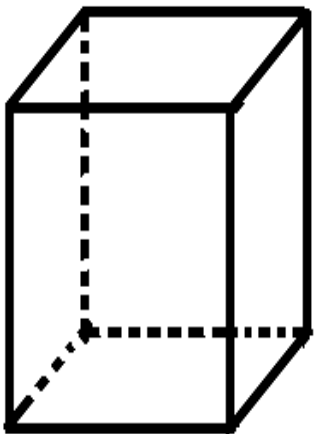

Une boîte de craies fermée

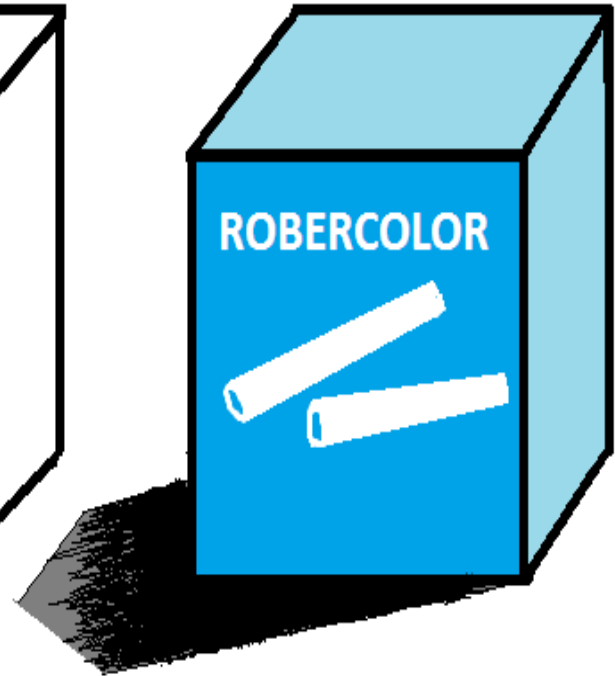
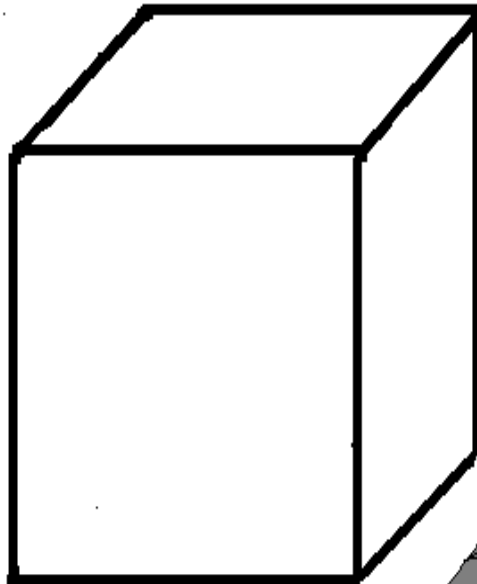
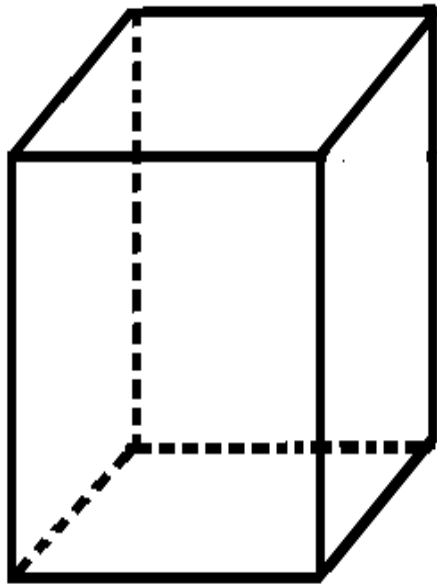

La chaise

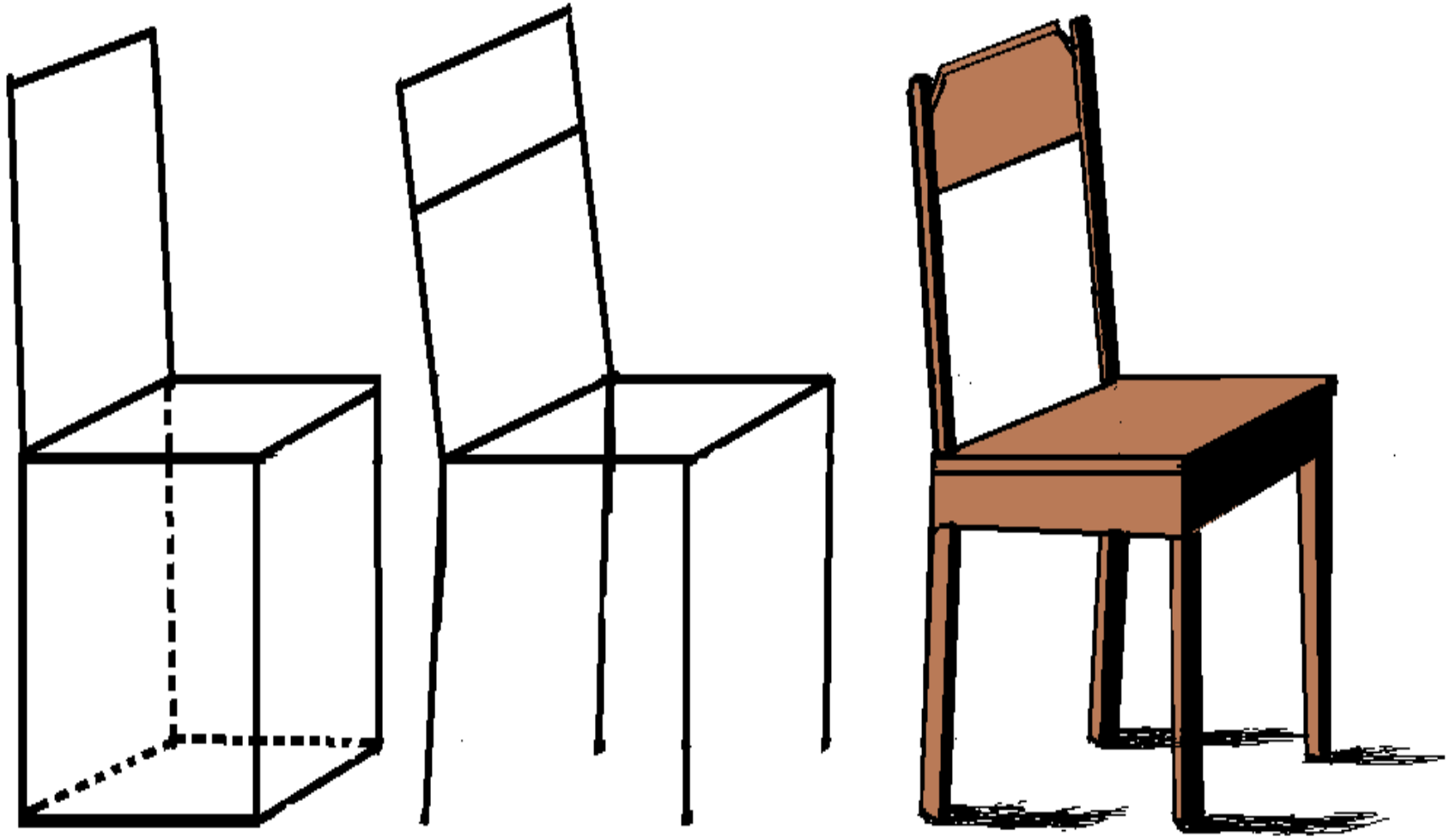

Le dé ludique

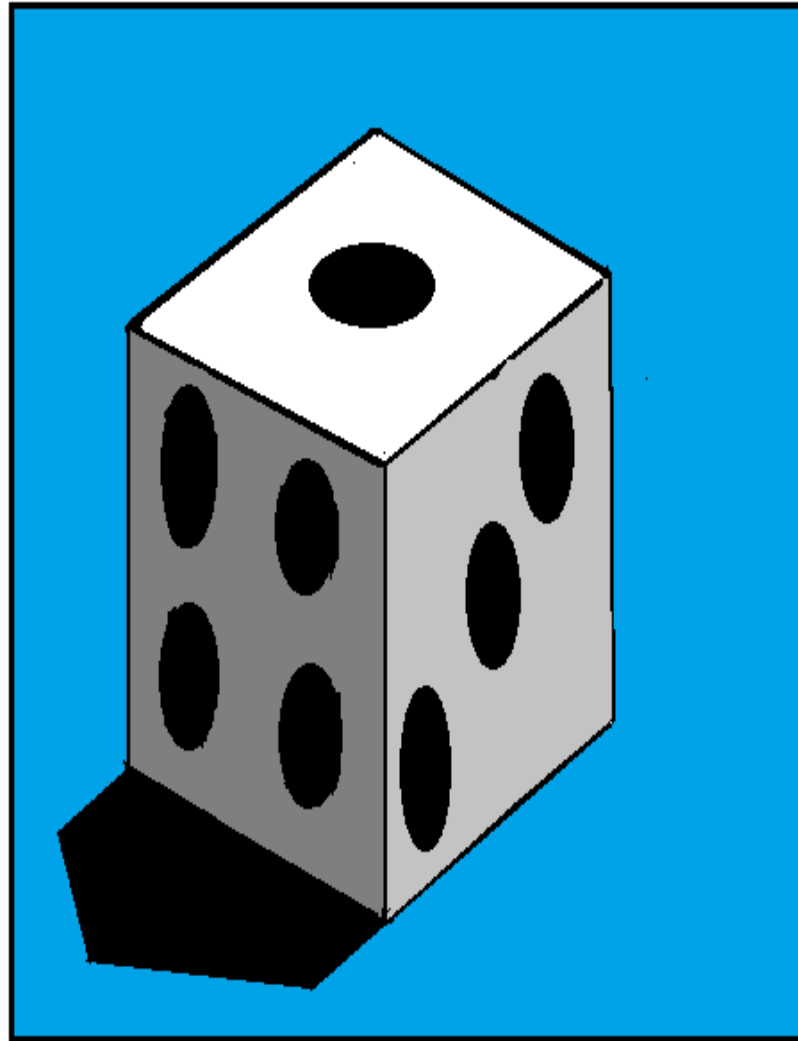
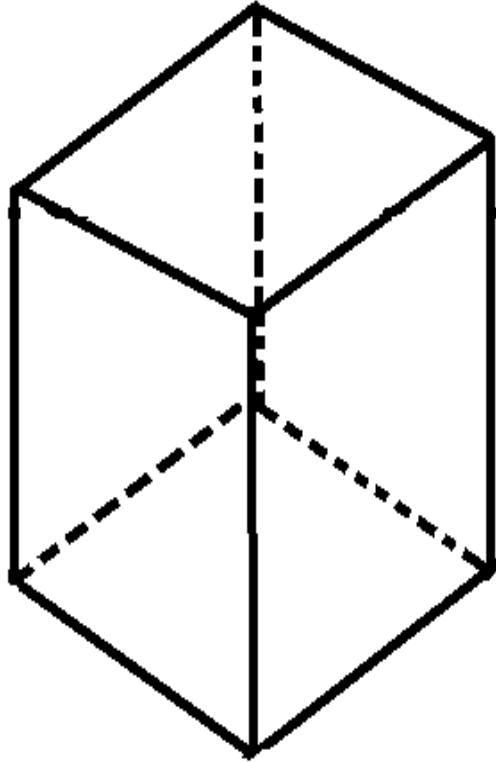

Les objets de forme parallélépipédiques

La table

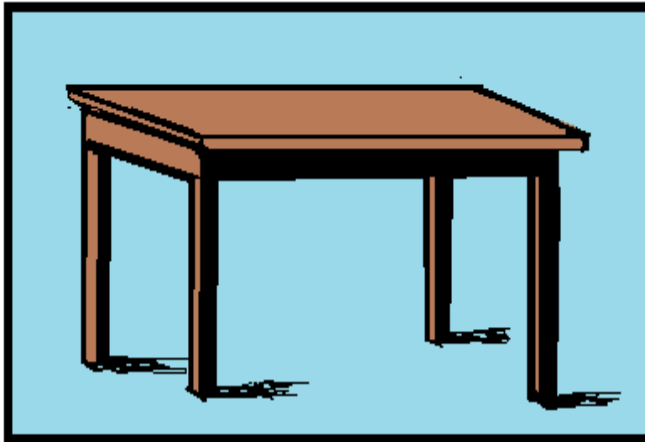
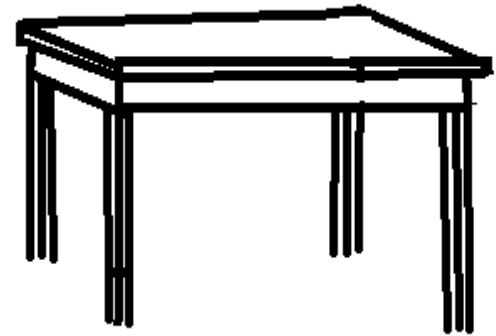
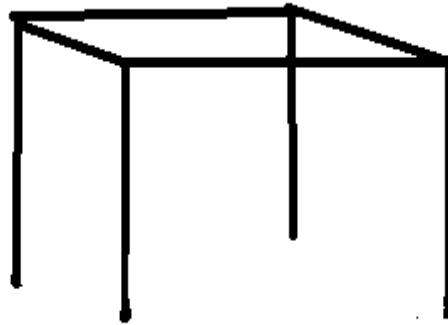
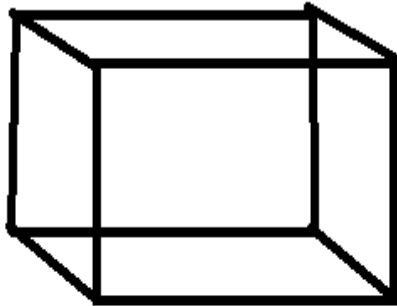

Le livre ouvert

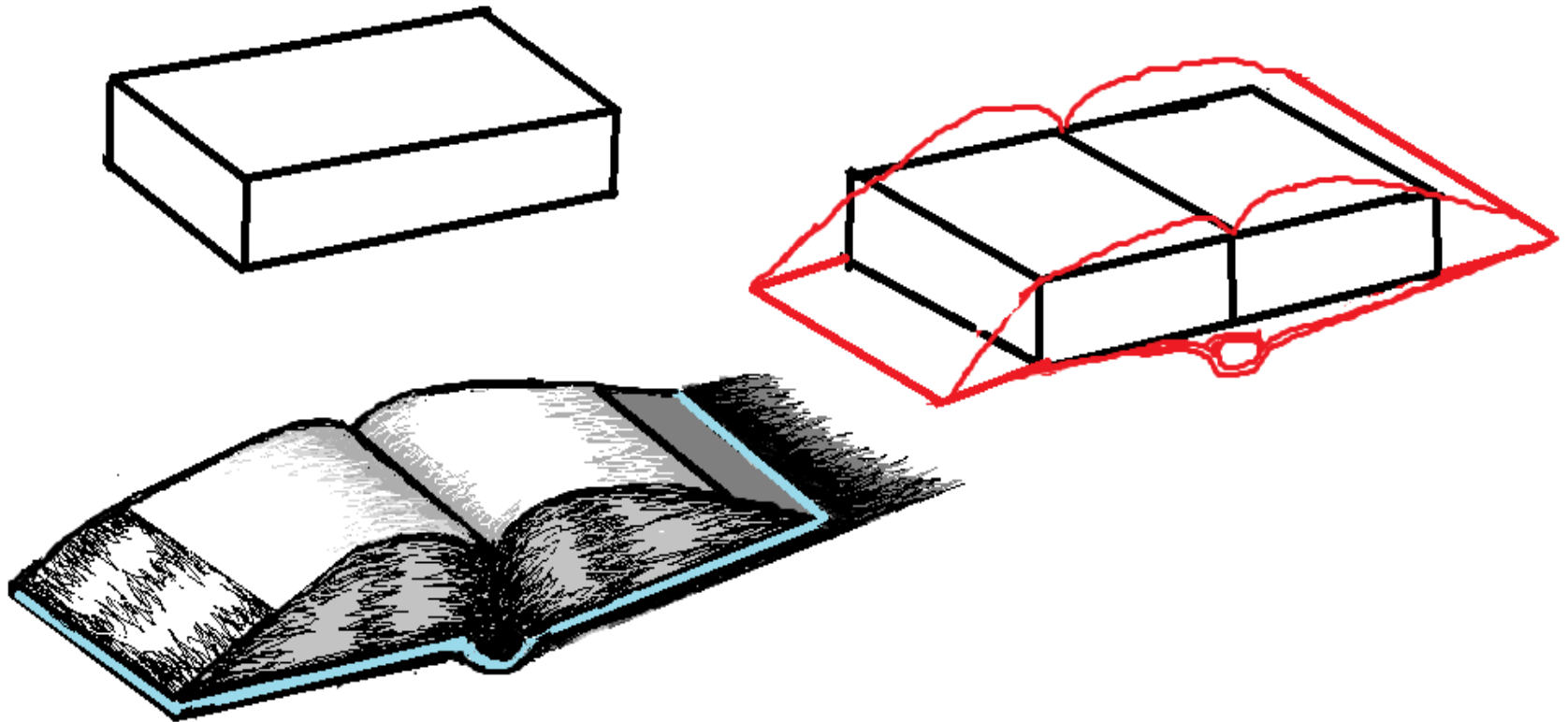

Le livre ouvert

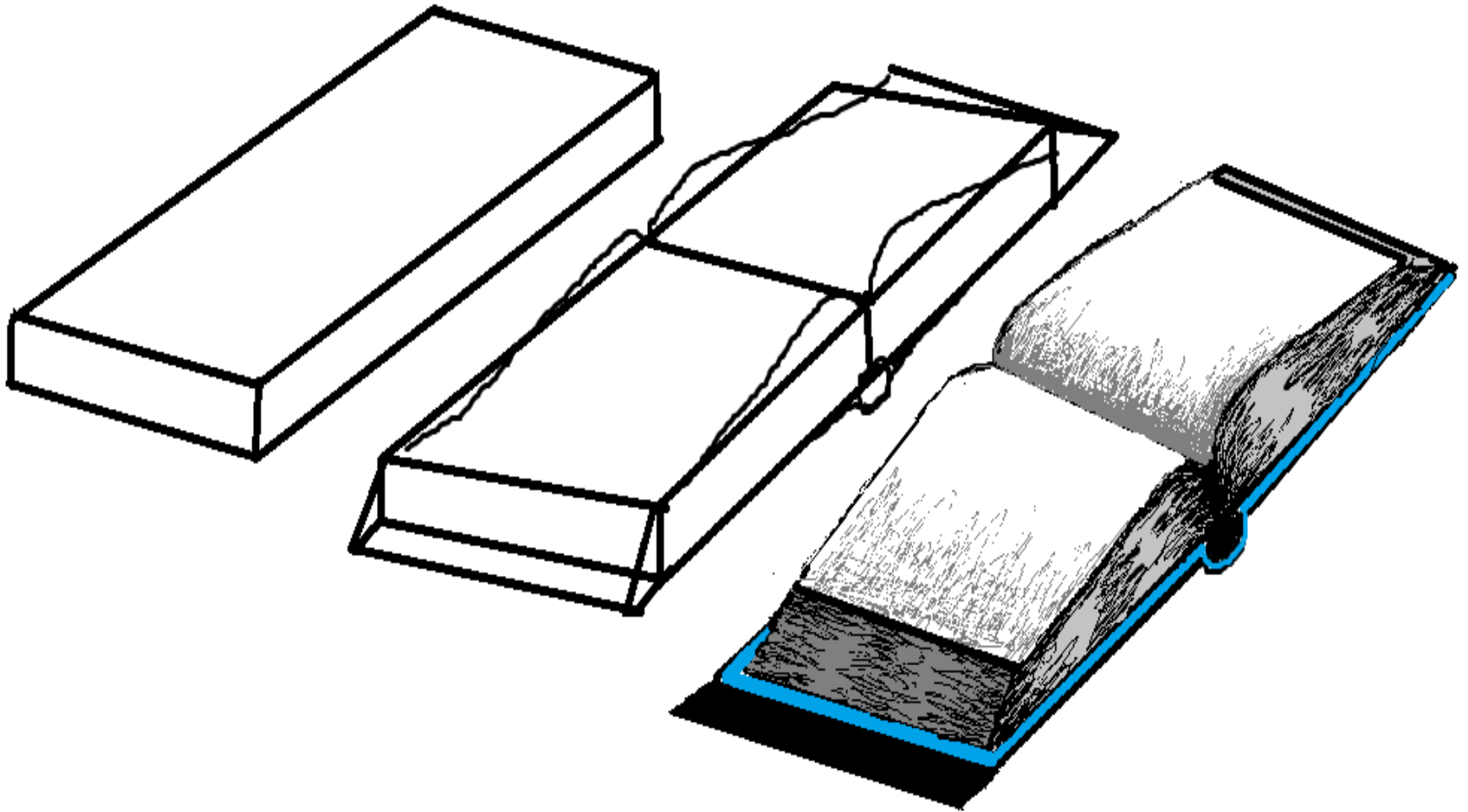

Le livre fermé

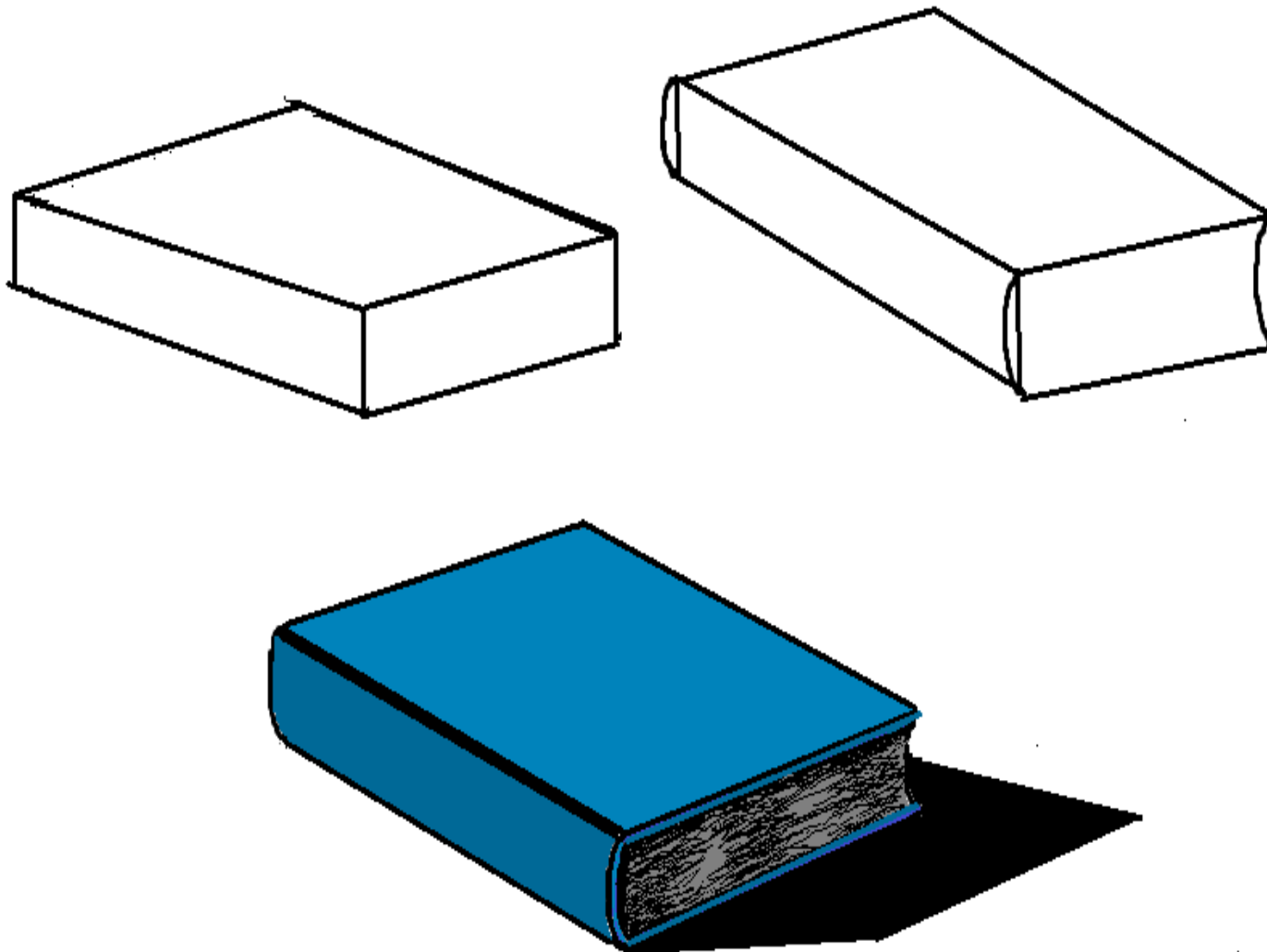

Une pile de livres

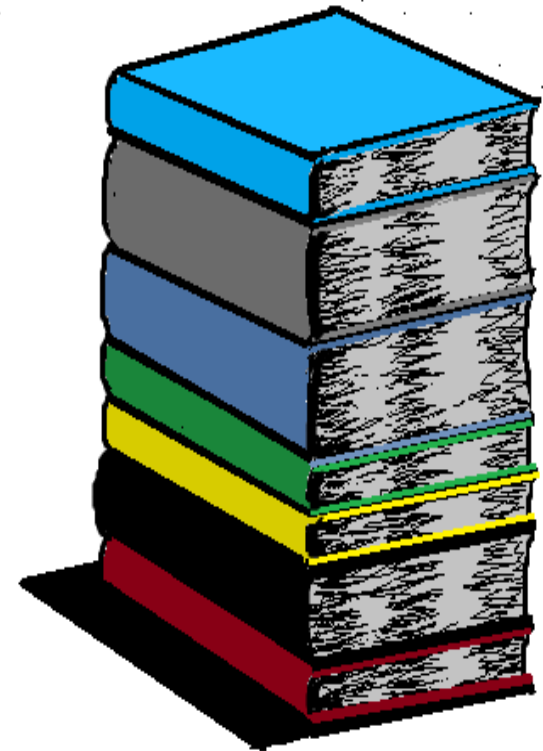
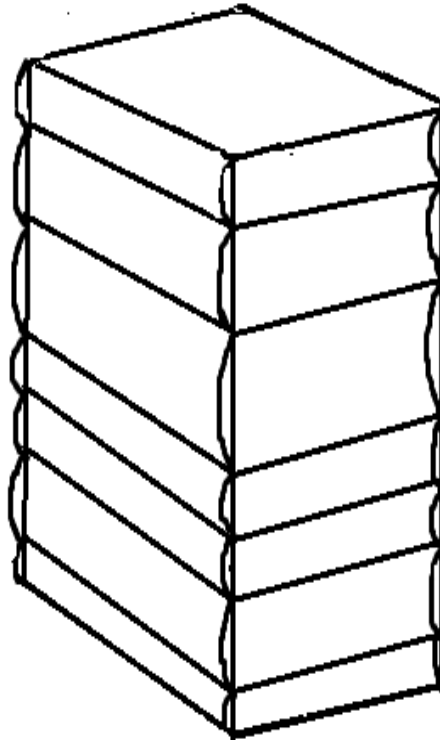
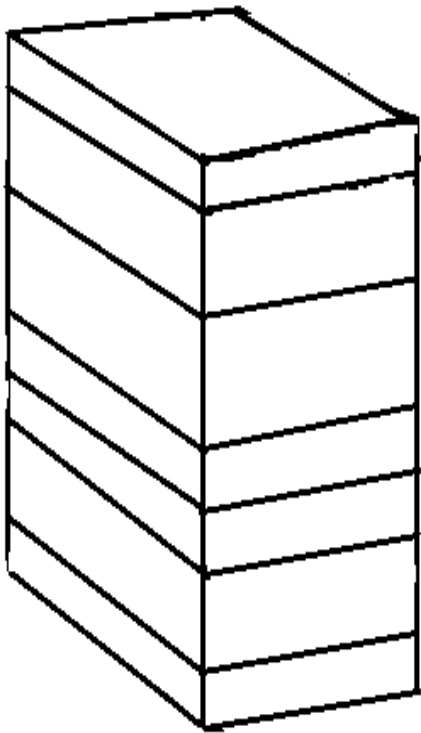

Un banc d'écolier (croquis et redressement)

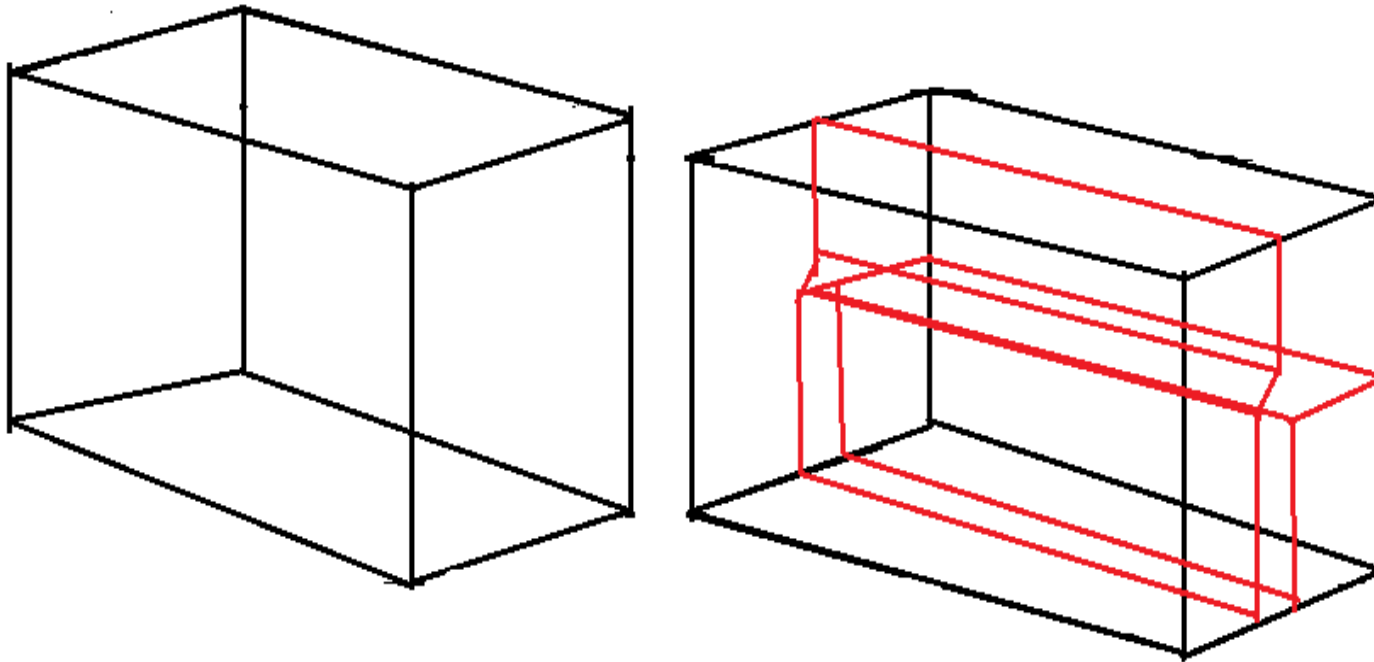

Un banc d'écolier (arrangement)

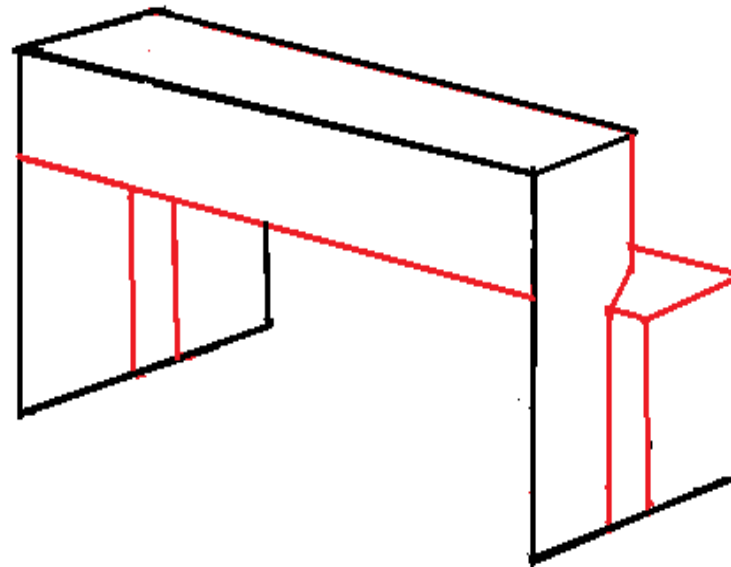

Un banc d'écolier (finition)

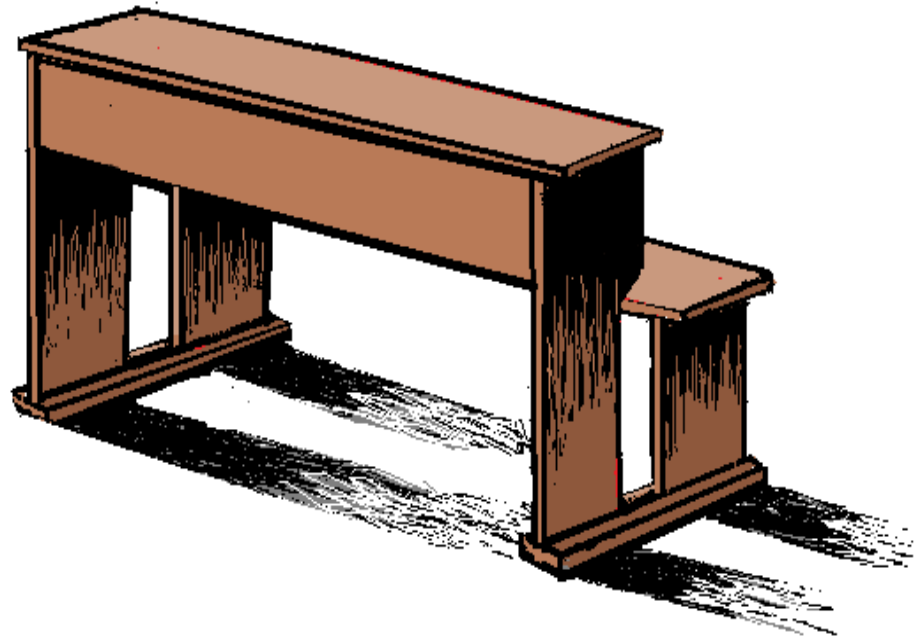

Une case

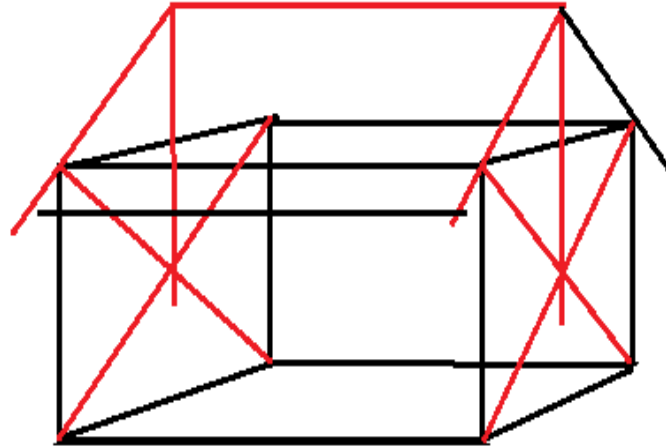
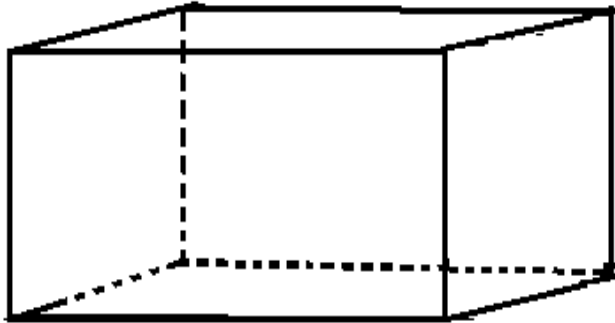

Un livre ouvert posé sur une table

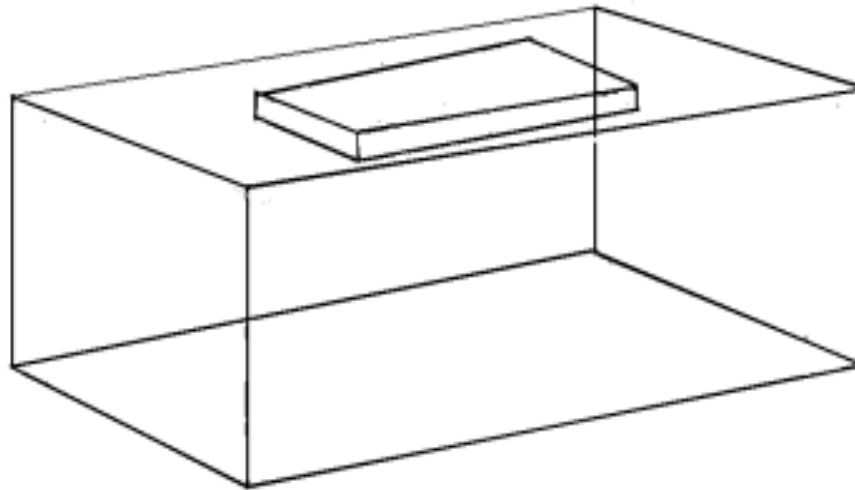

Un livre ouvert posé sur une table

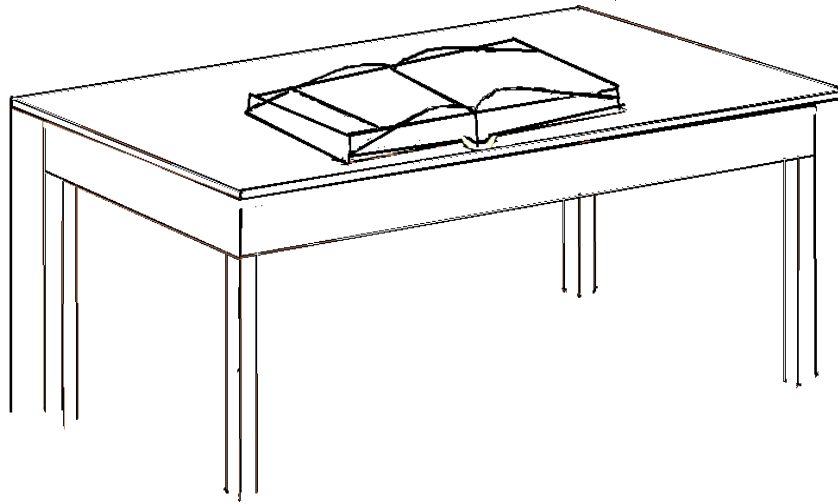

Un livre ouvert posé sur une table

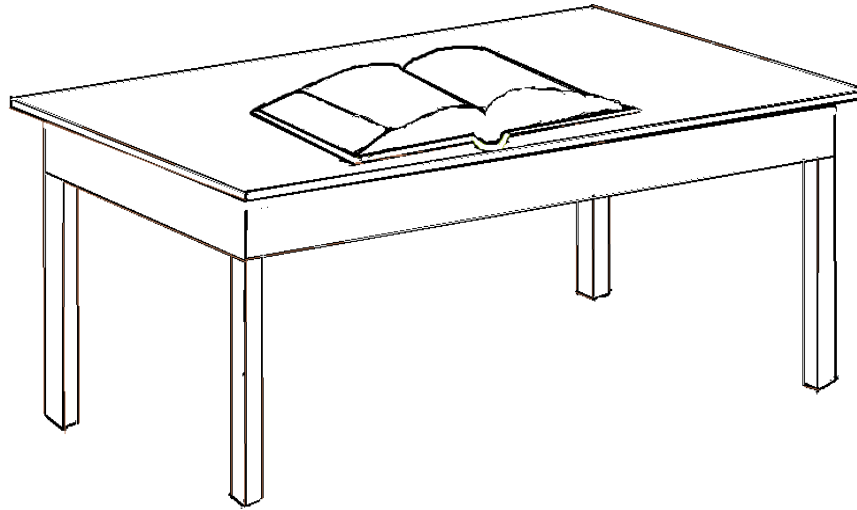

Un livre ouvert posé sur une table

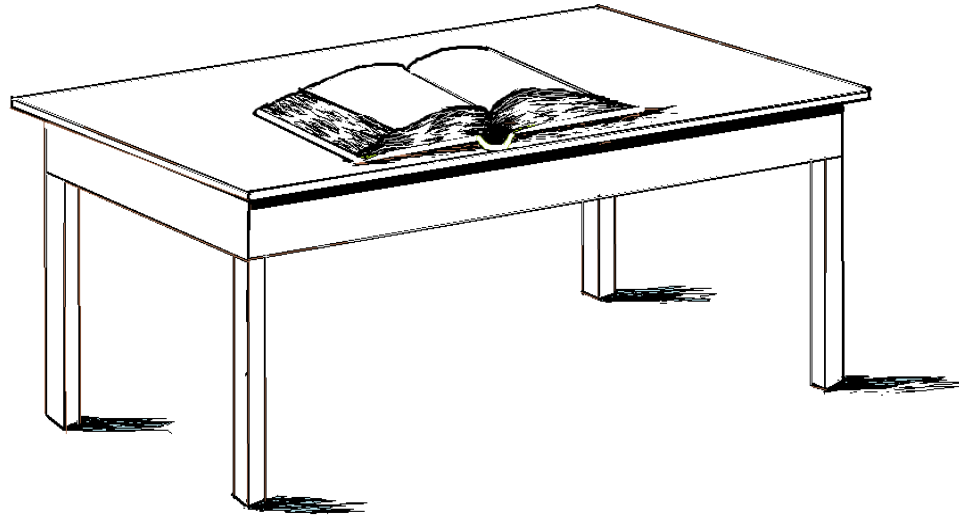

Un livre ouvert posé sur une table

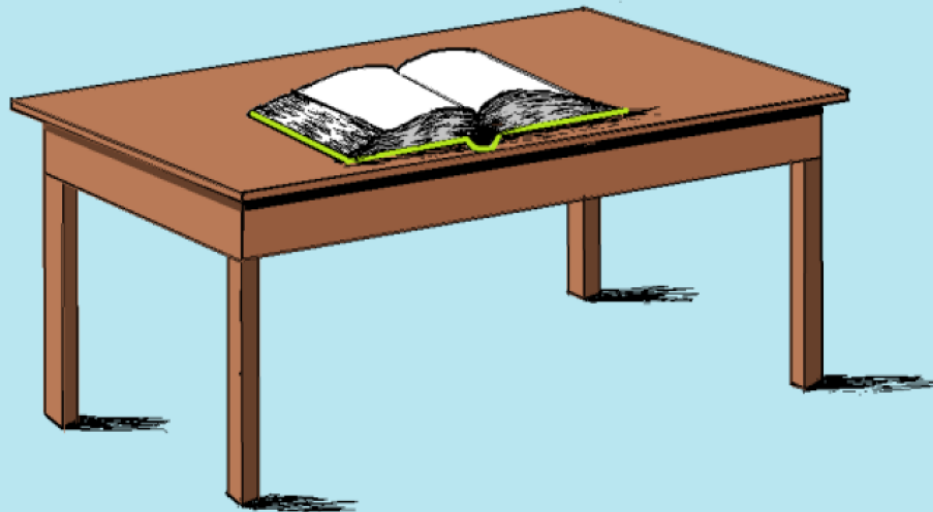

La radio

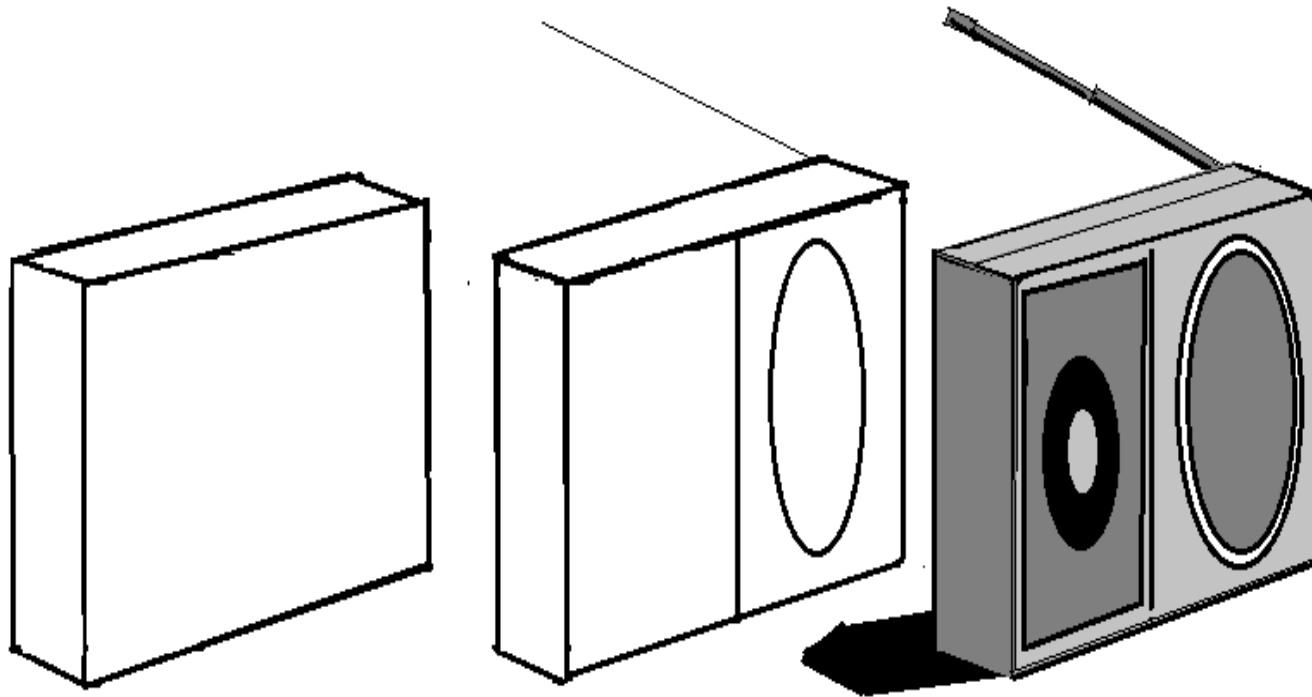

La télévision

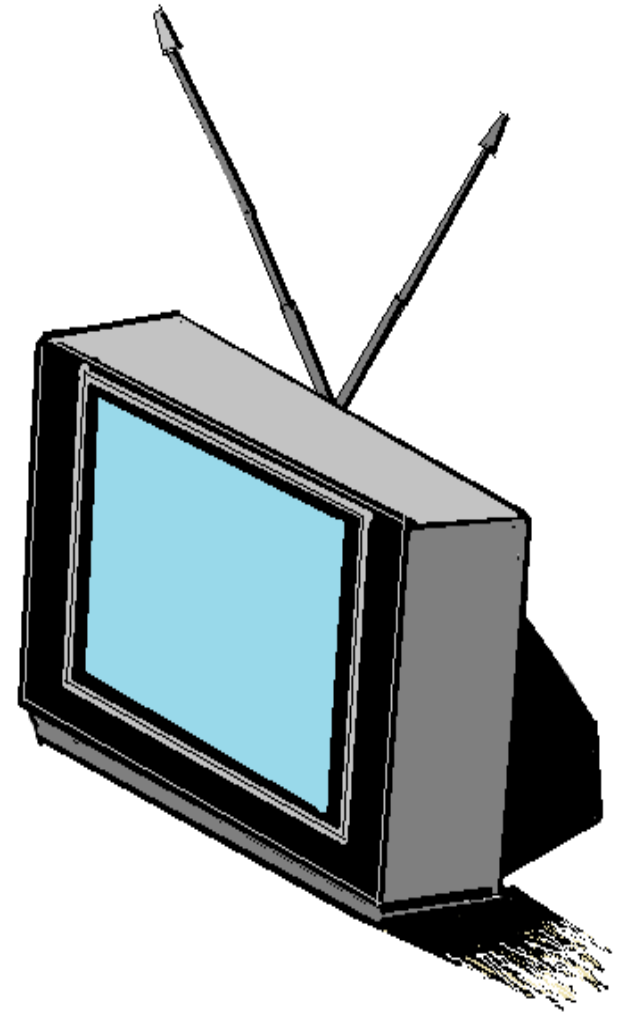
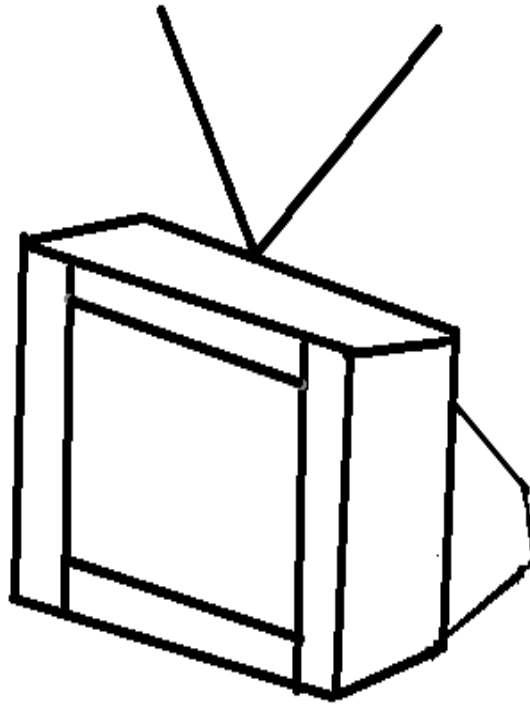
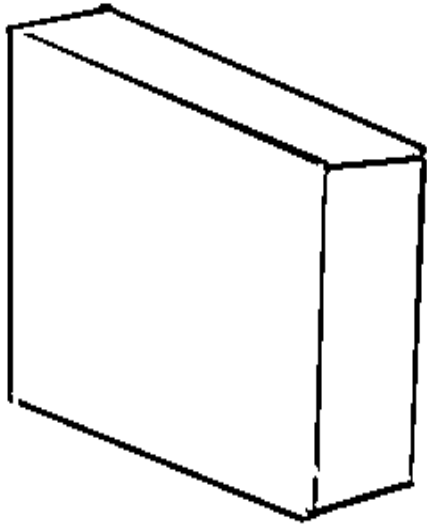

Le téléphone portable

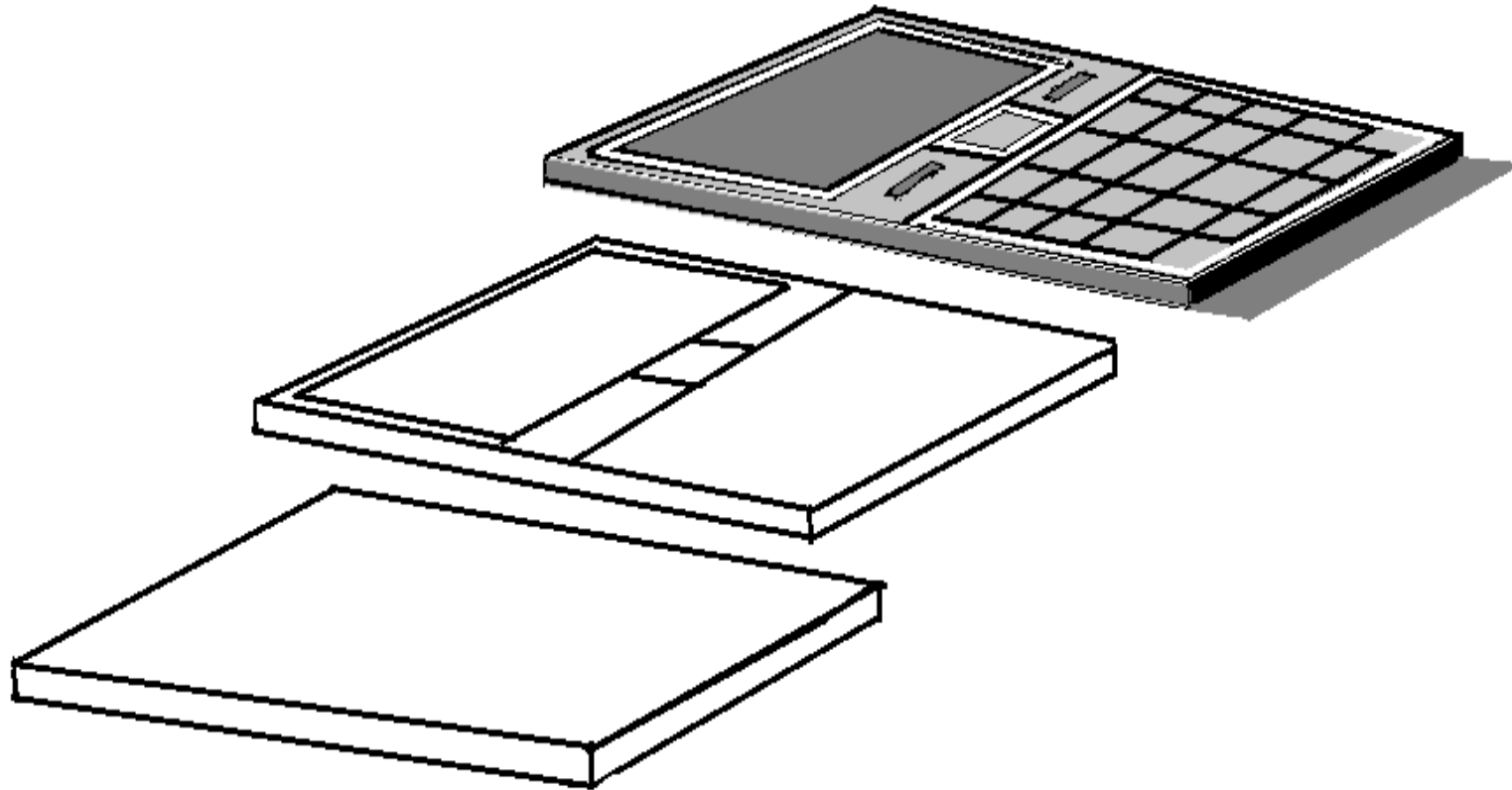

Une voiture

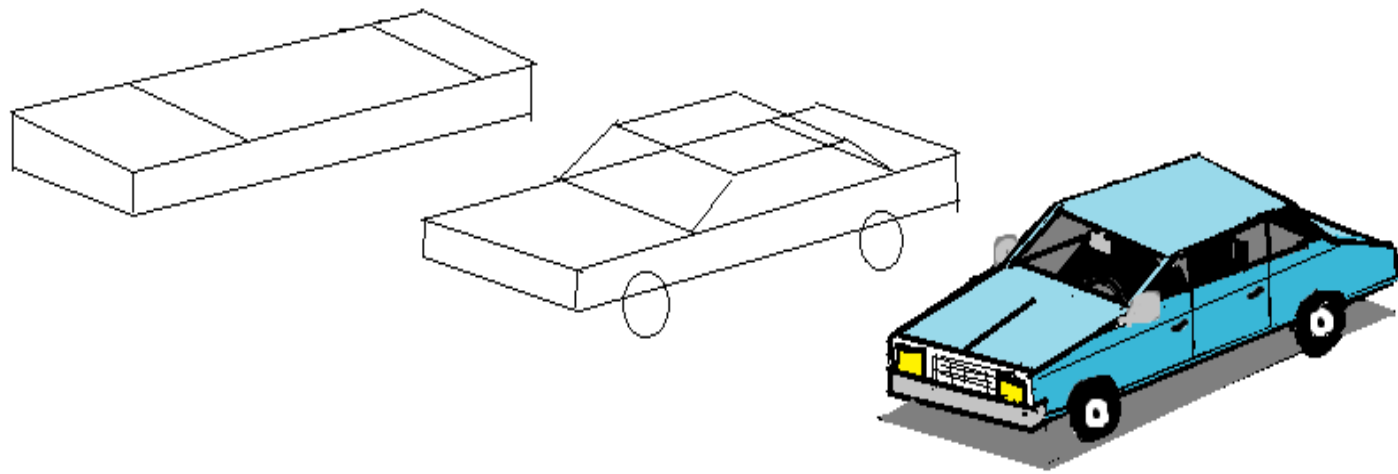

Le foyer traditionnel

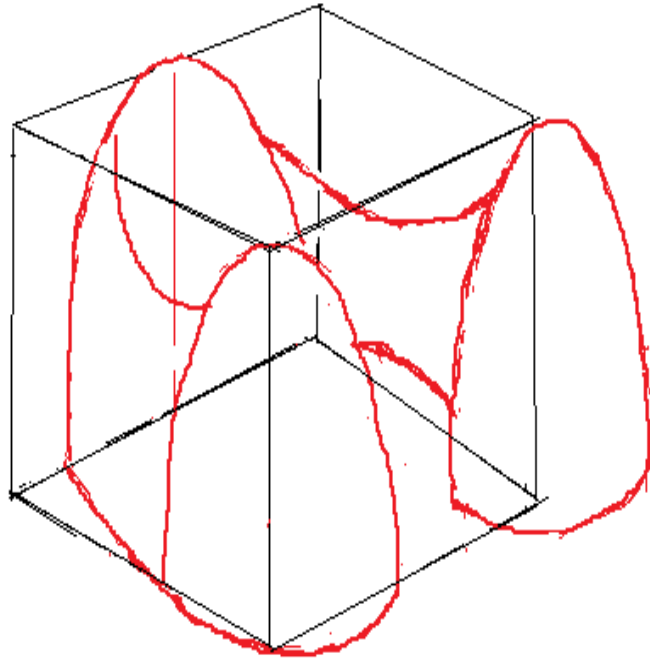
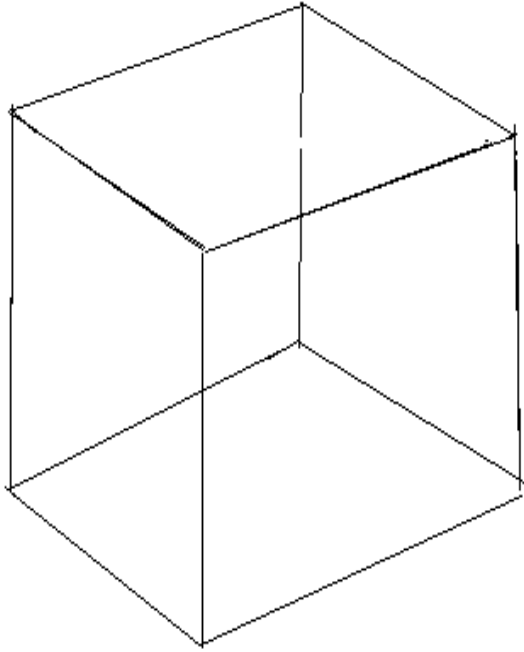

Le foyer traditionnel

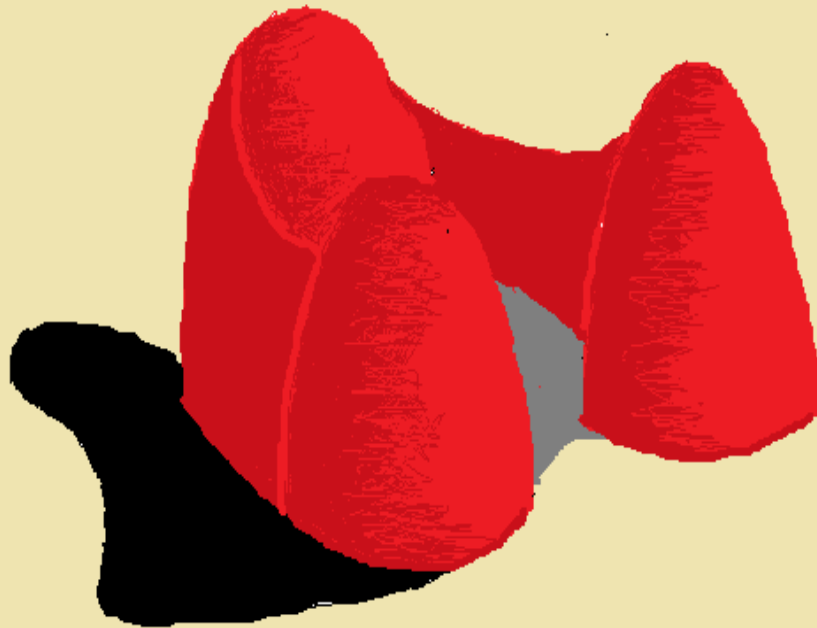

Les lunettes

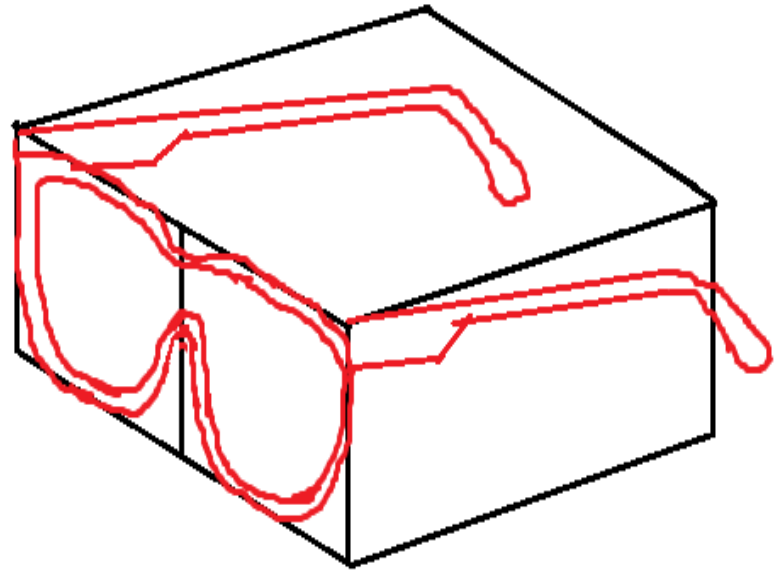
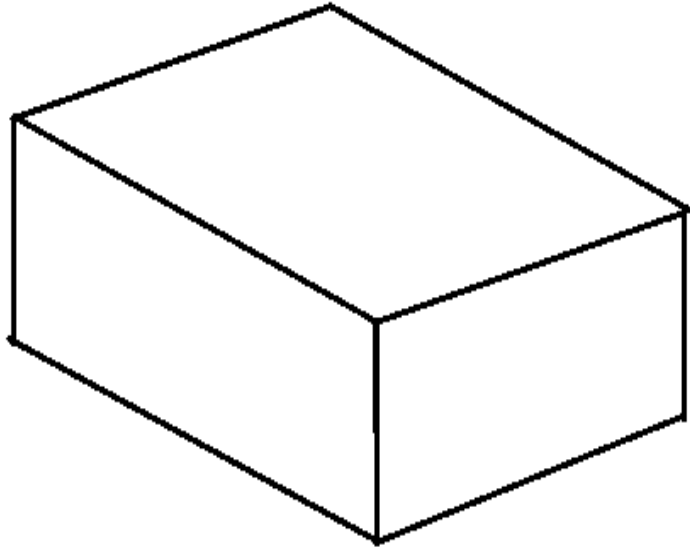

Les lunettes

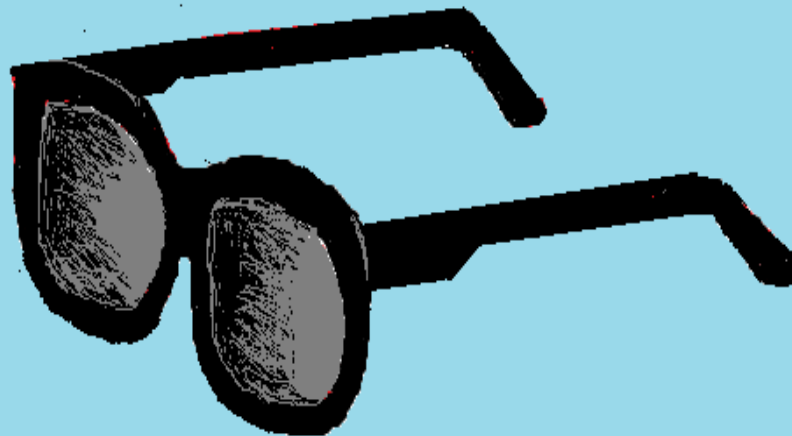

Les objets de forme cylindrique

La bouteille et le verre



Le mortier

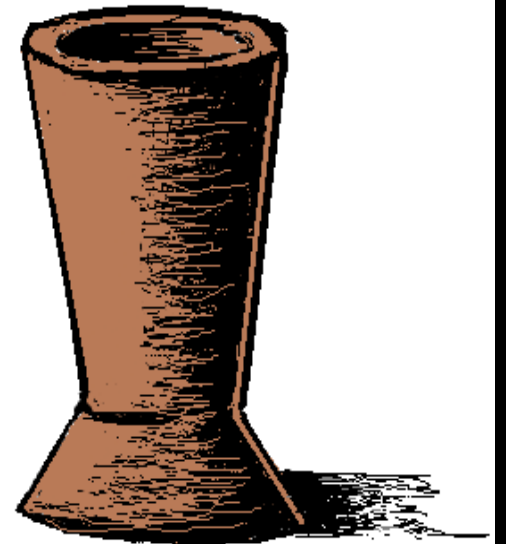
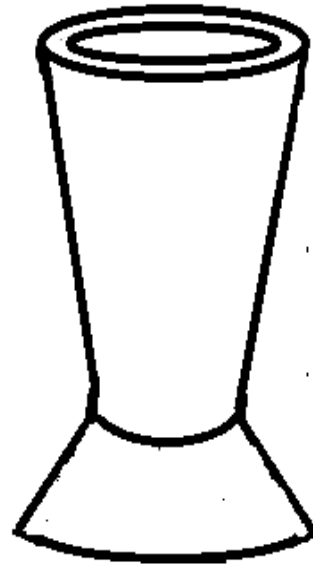
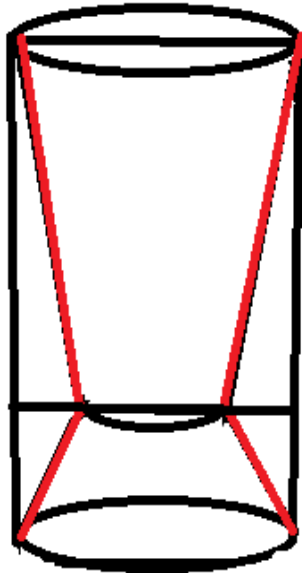
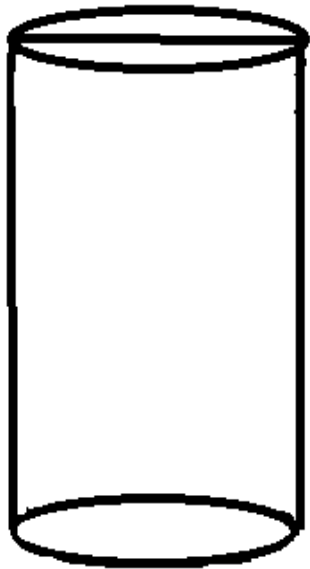

Le tonneau

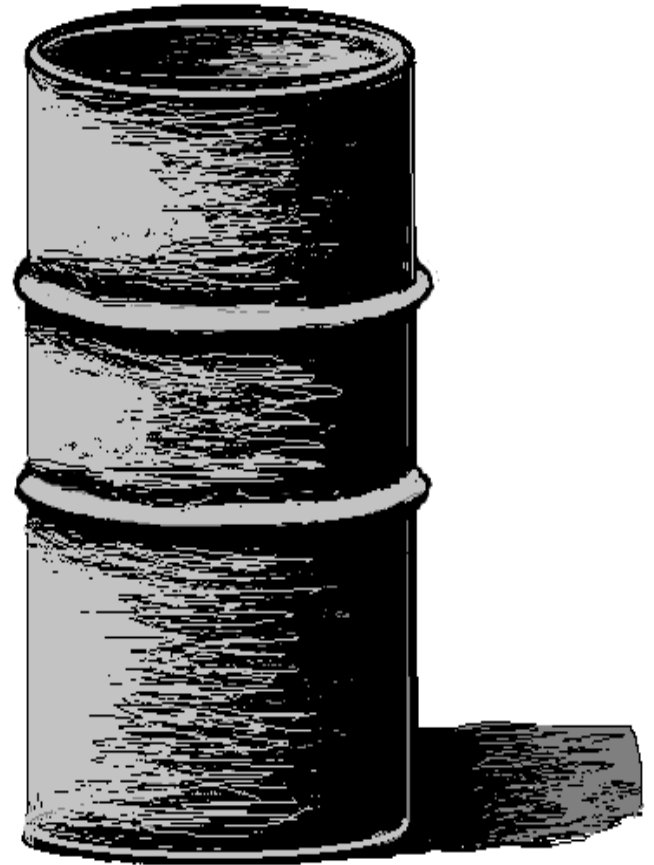
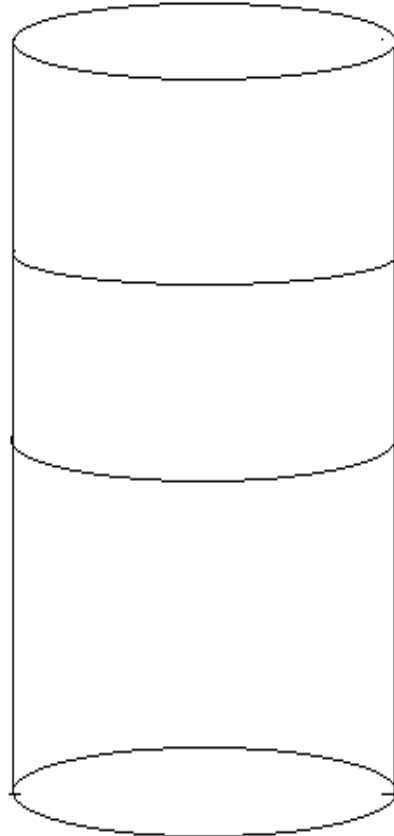
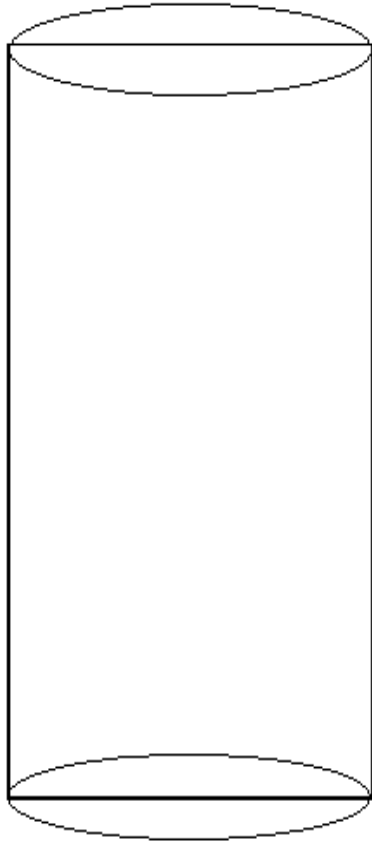

La casserole

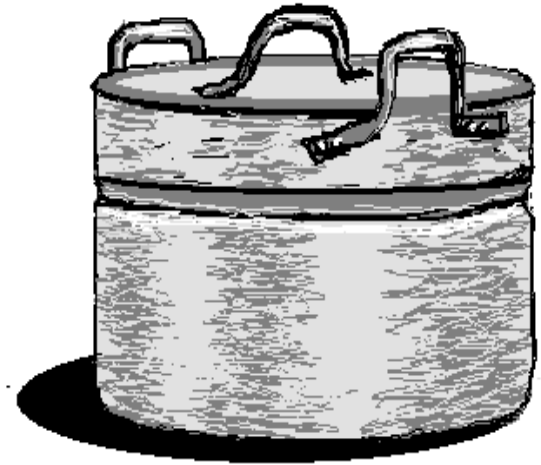
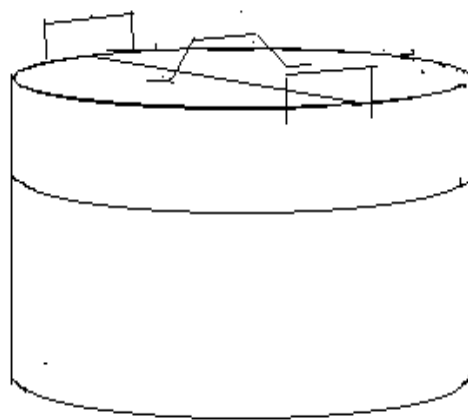
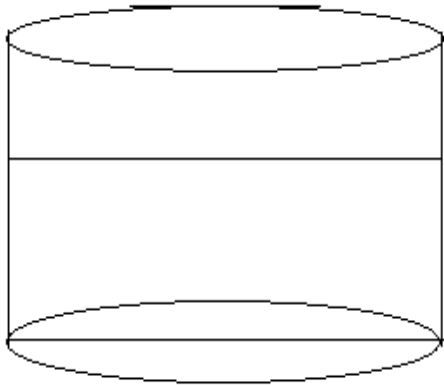

Le seau

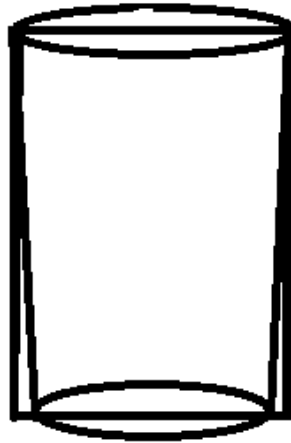
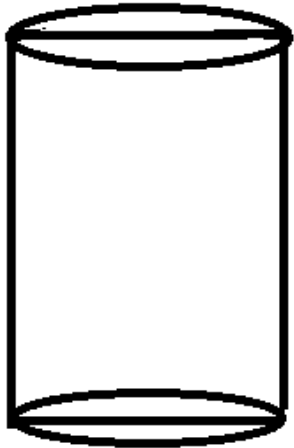

Le gobelet

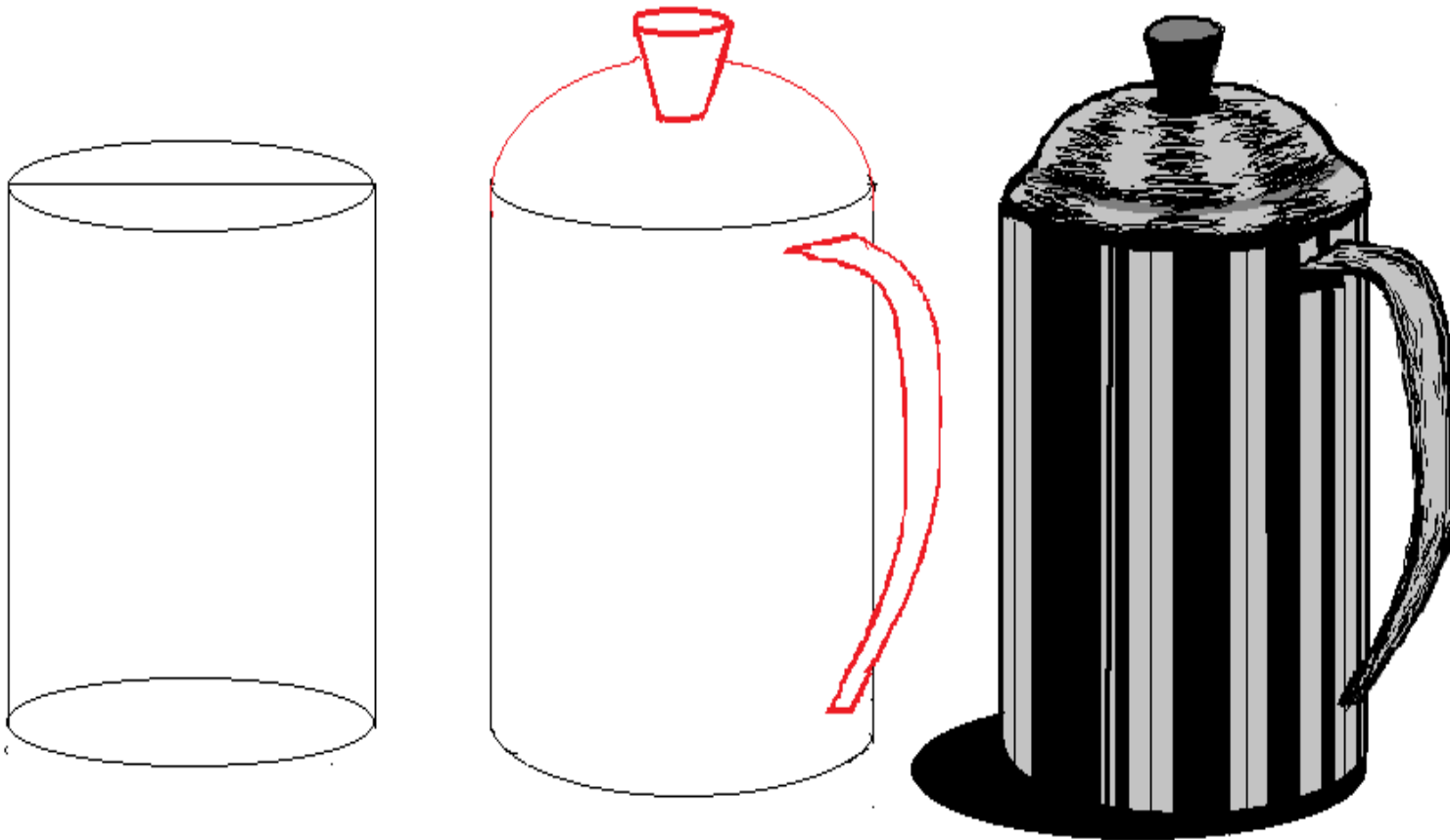

La torche

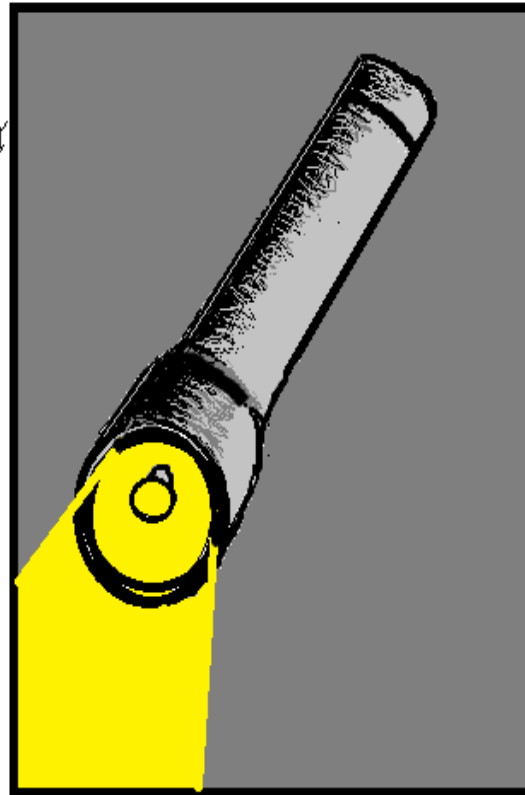
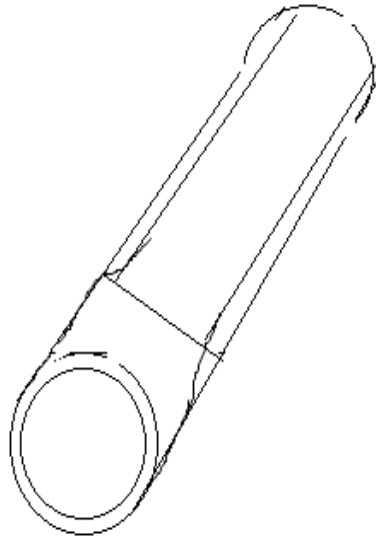
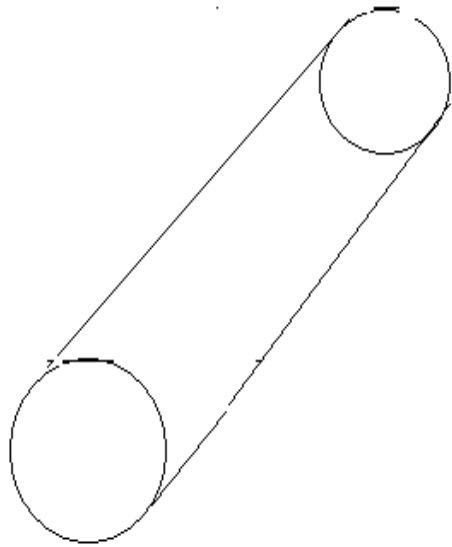

Les formes sphériques

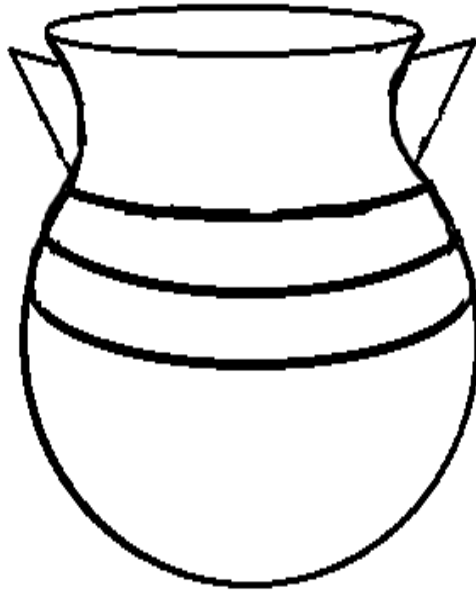
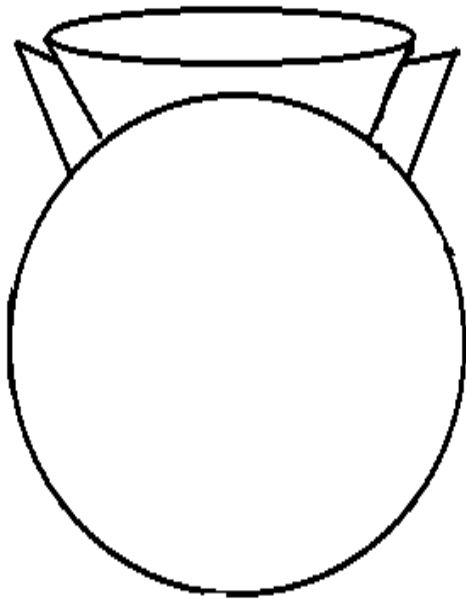

Le ballon de foot

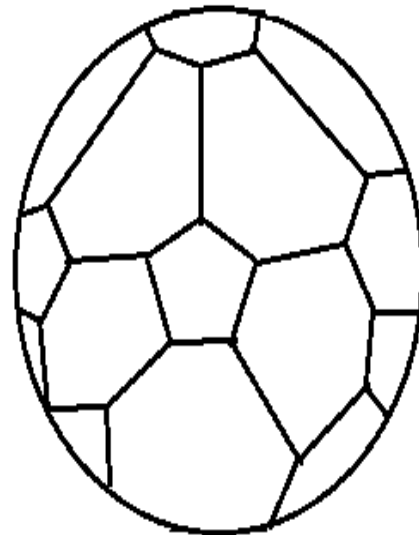
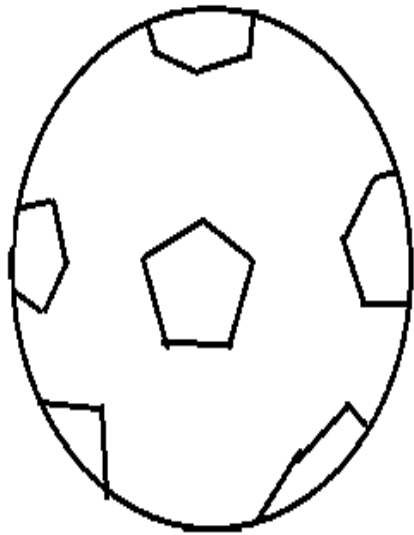

Le canari

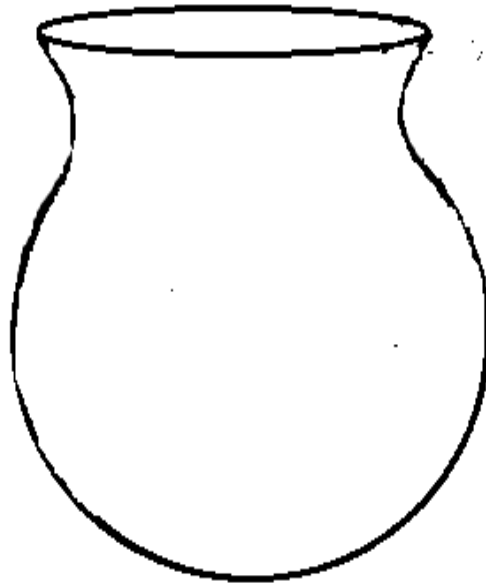
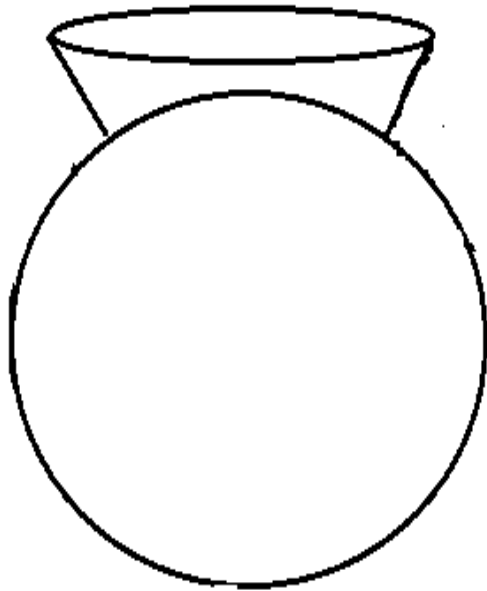

La calébase

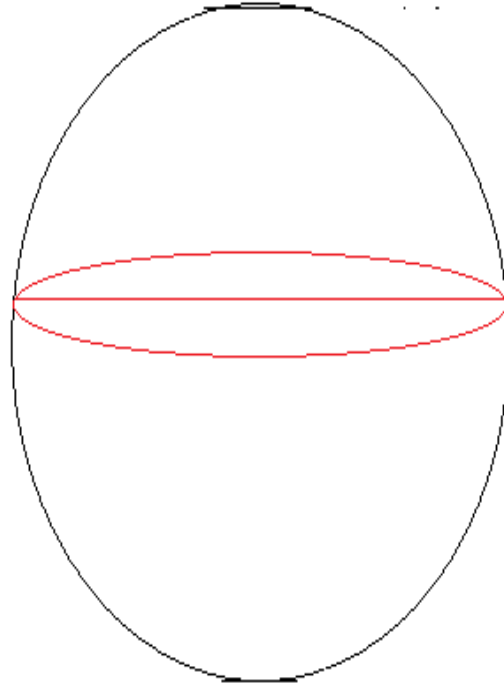
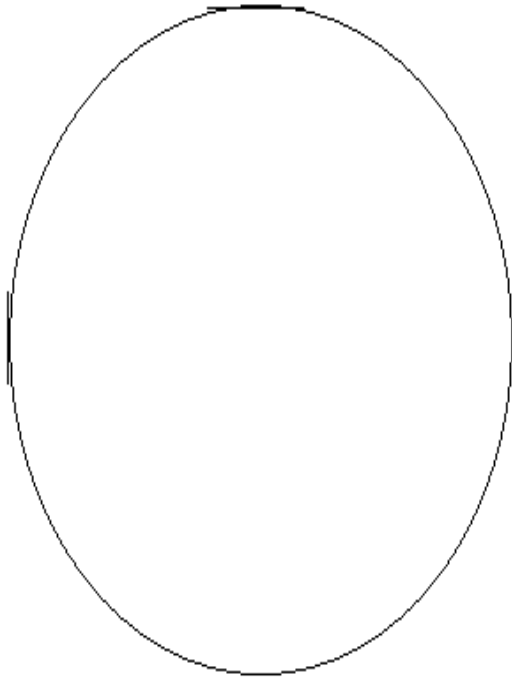

Les oranges regroupées (croquis)

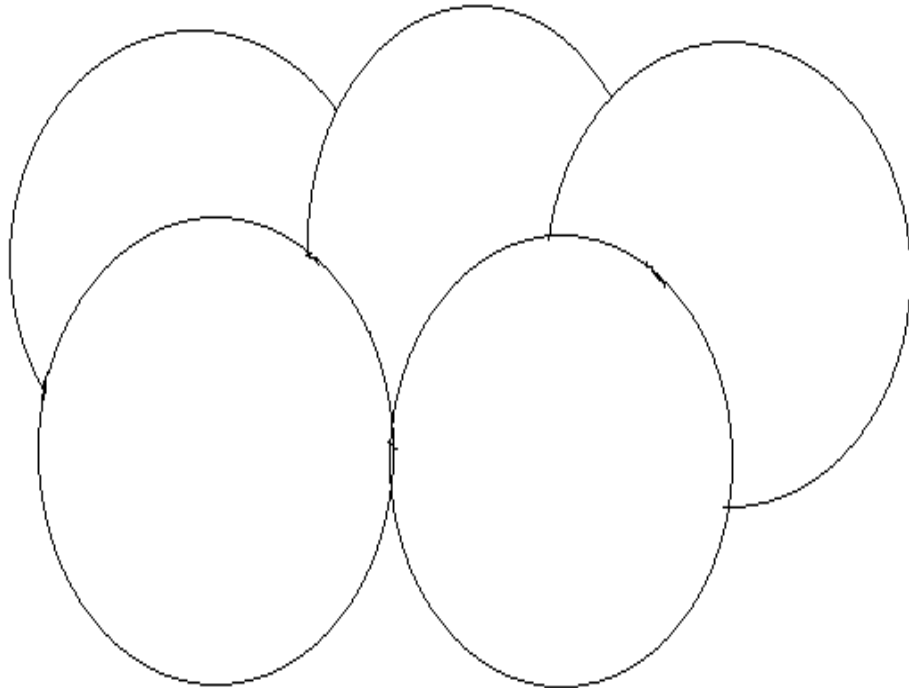

Les oranges regroupées (redressement et arrangement)

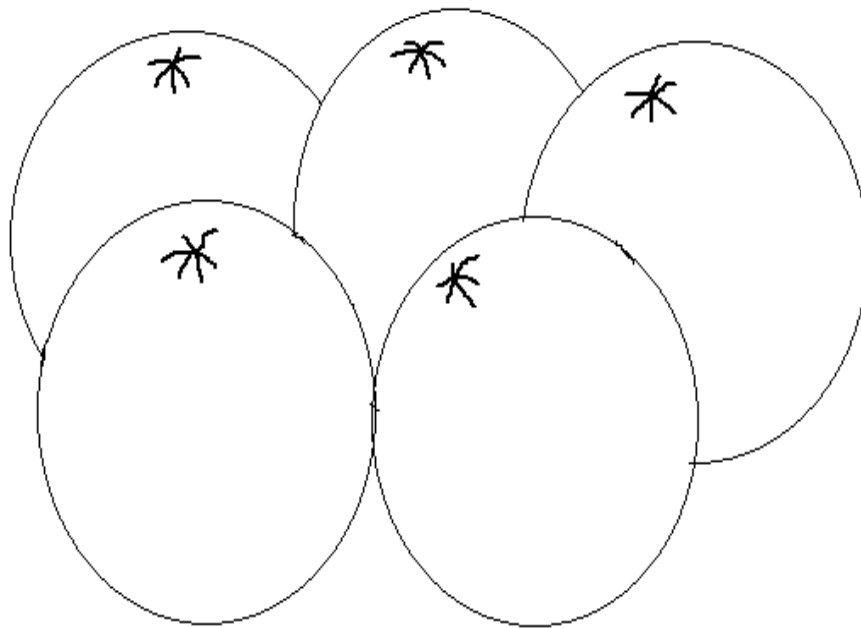

Les oranges regroupées(finition)

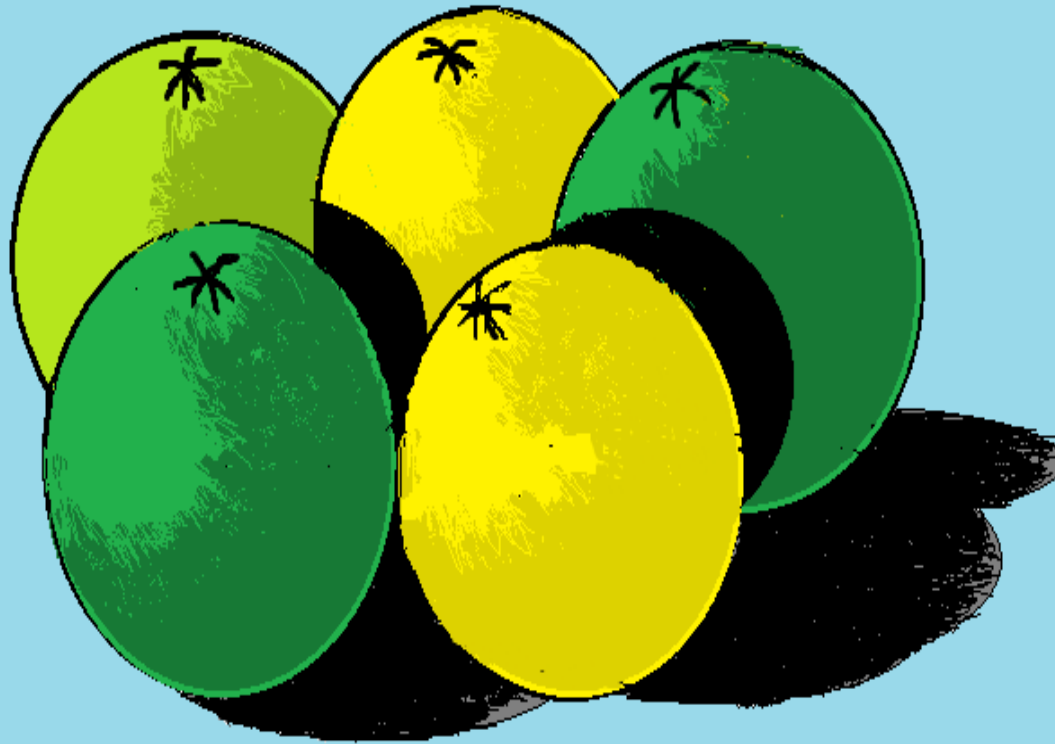

Les objets de forme conique

Case ronde couverte de pailles

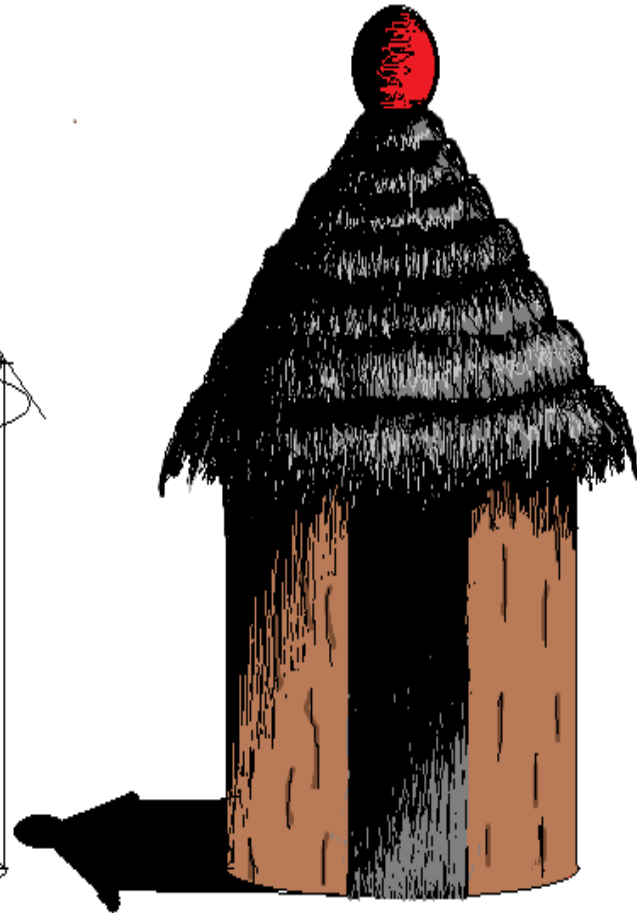
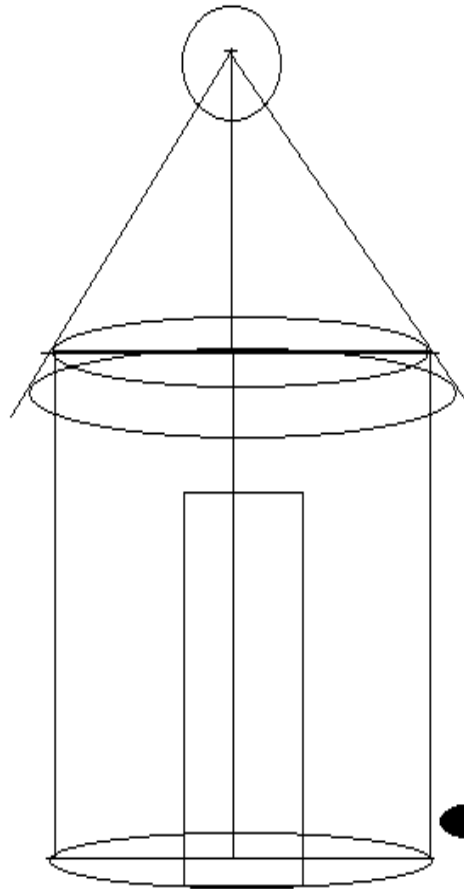
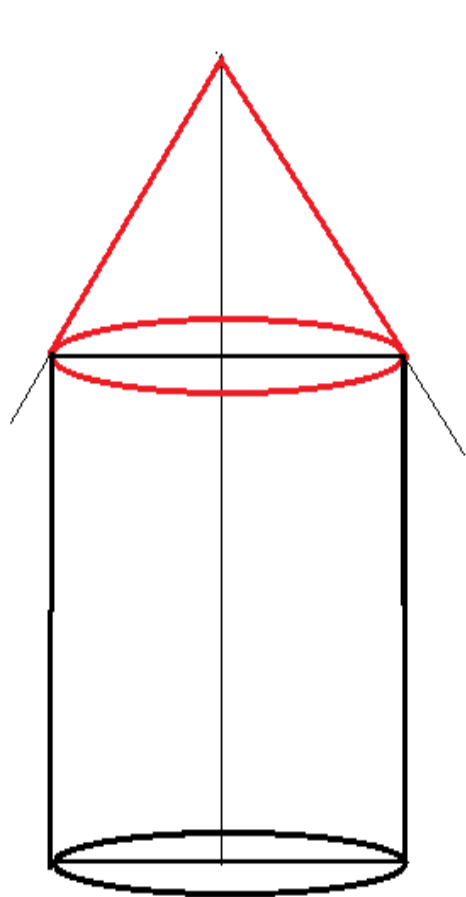

Une paillette

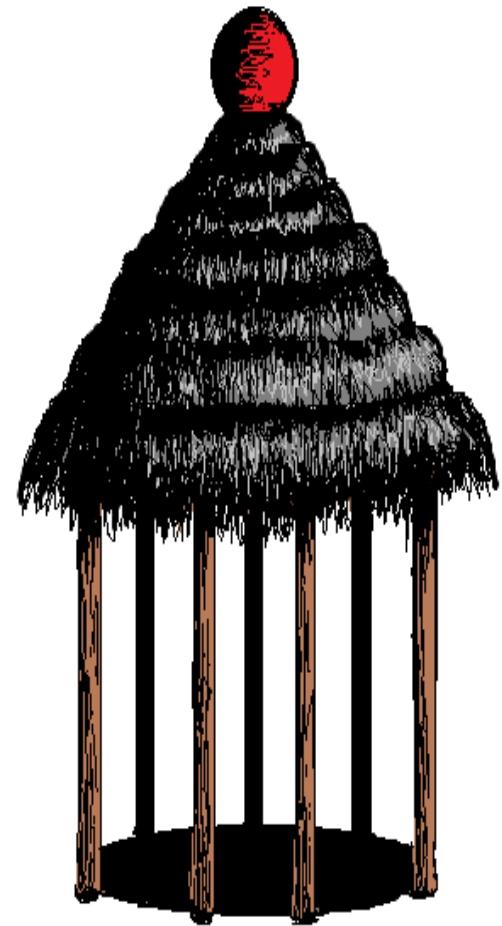
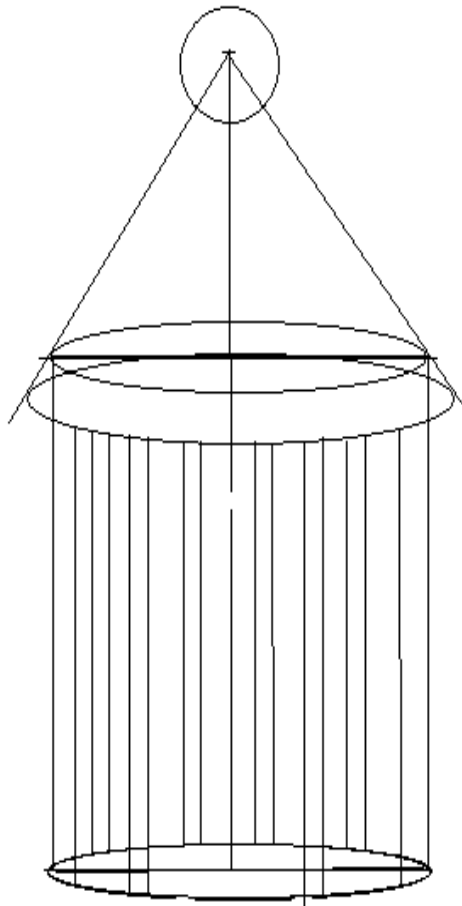
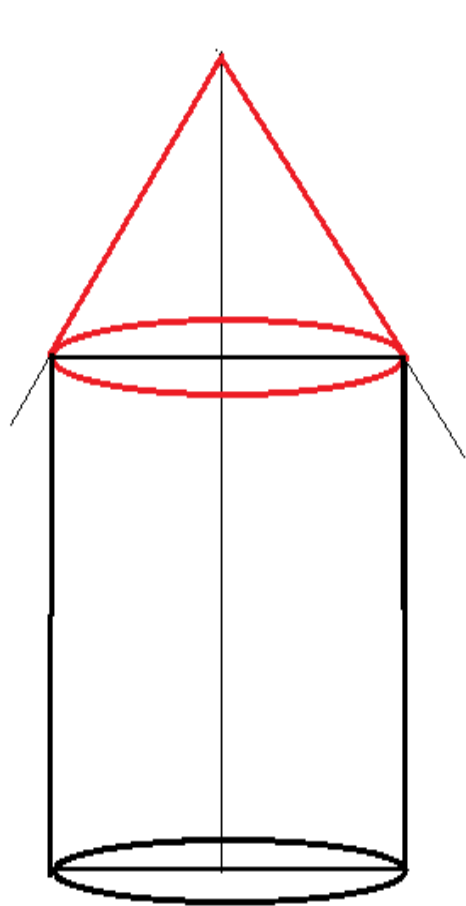

Un entonnoir

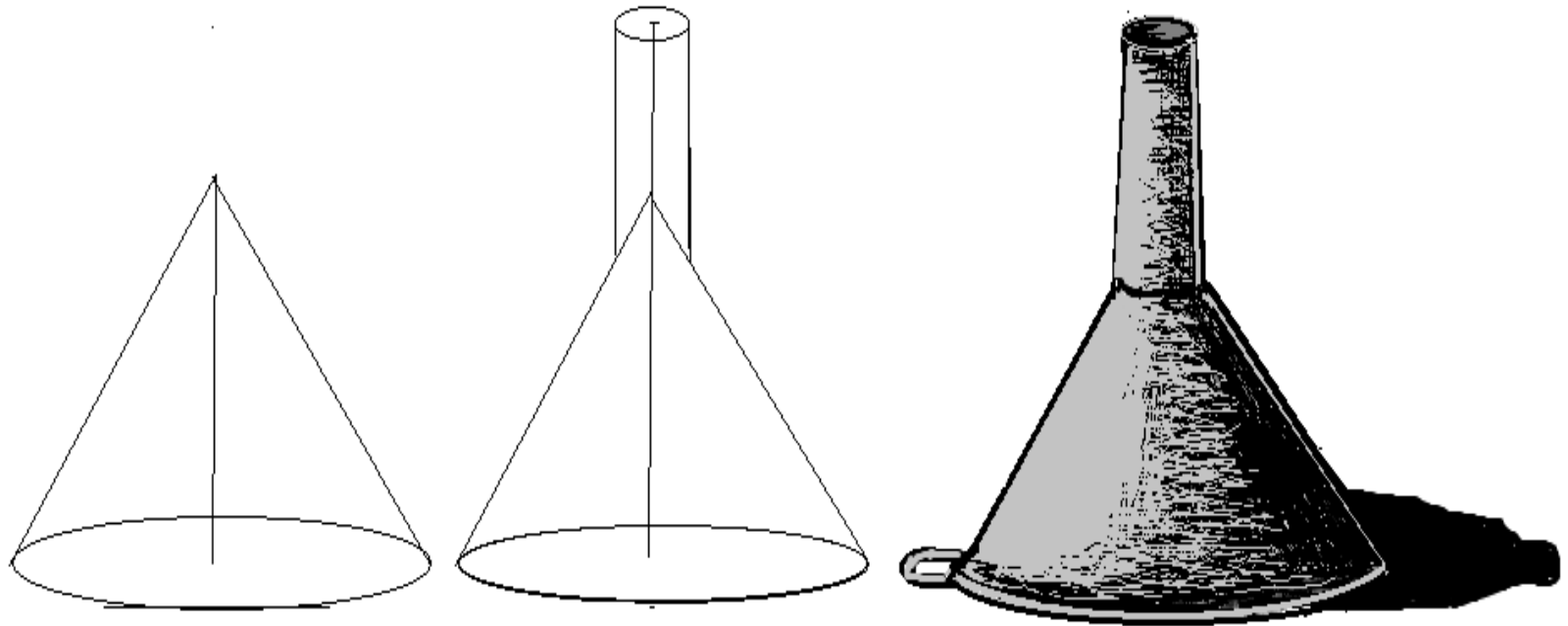

Les objets de forme prismatique un bâtiment ou une case

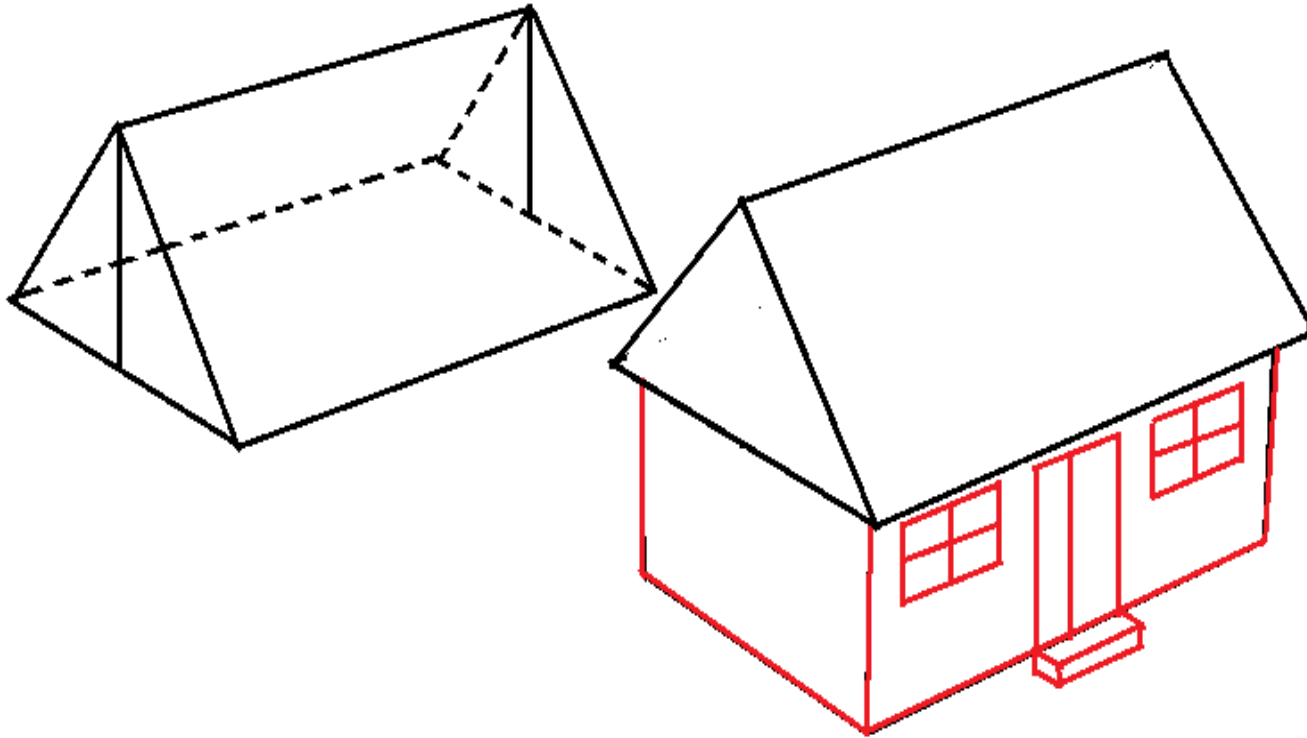

Un bâtiment ou une case



Les dessins d'objets par les formes planes

Le papillon

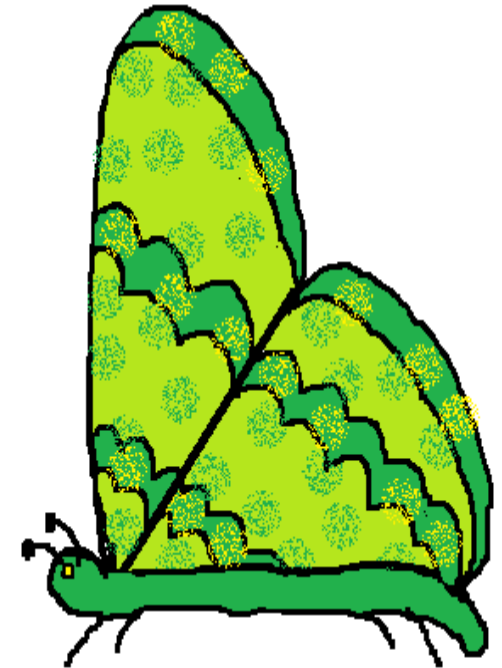
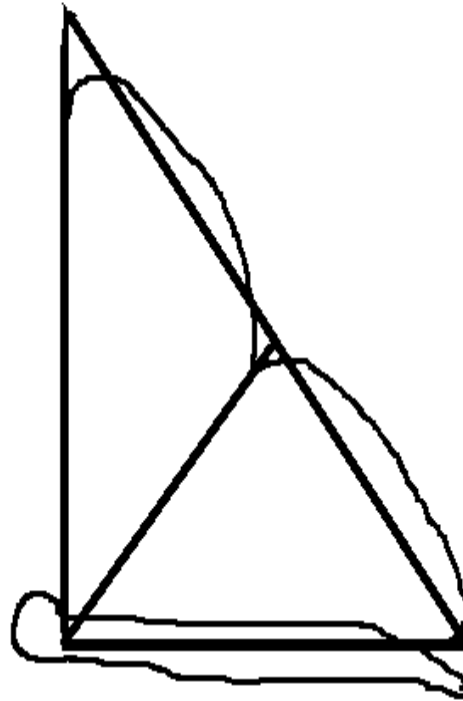
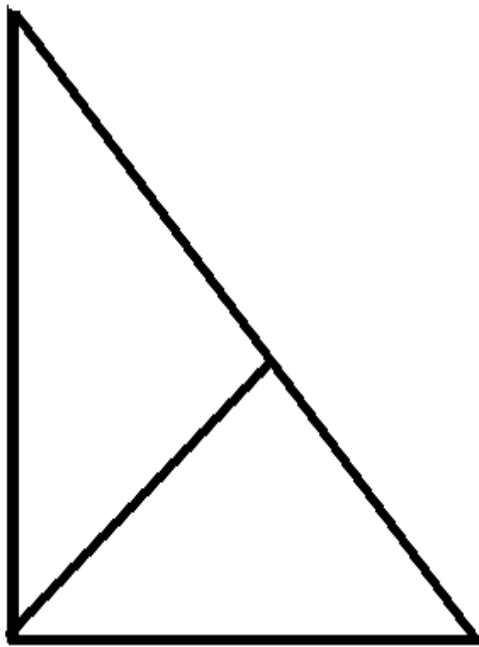

Le papillon

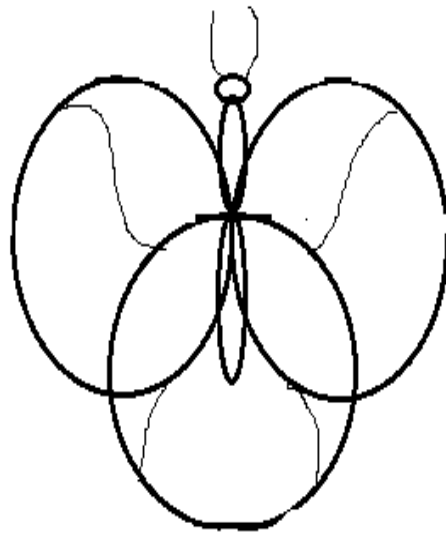
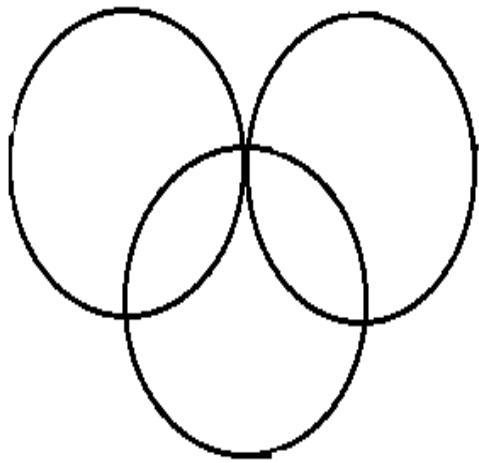

L'éléphant

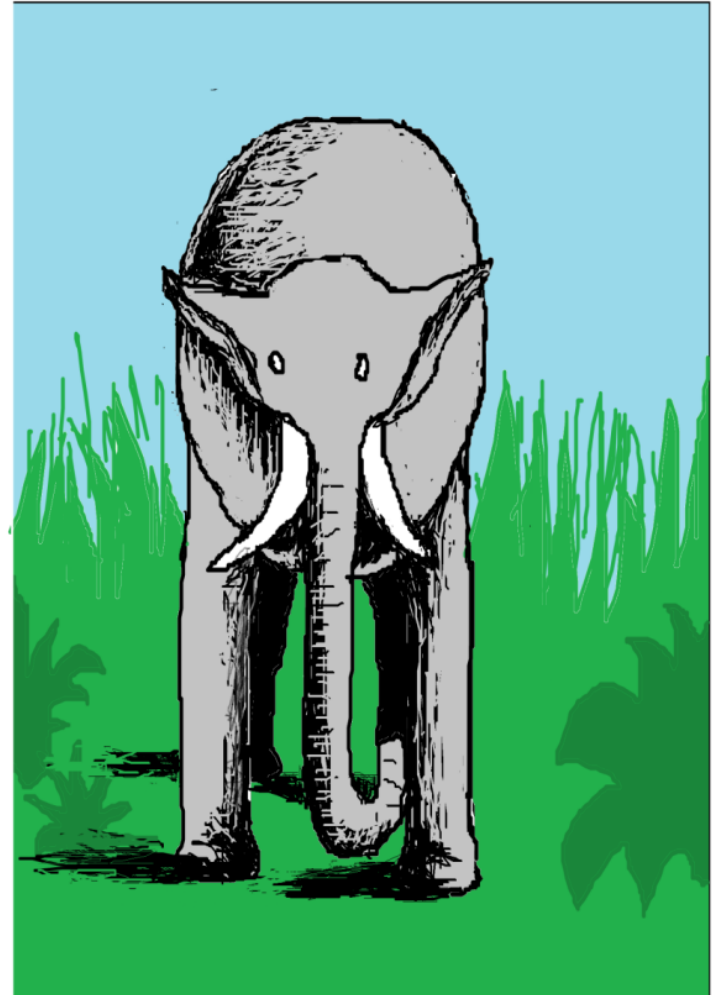
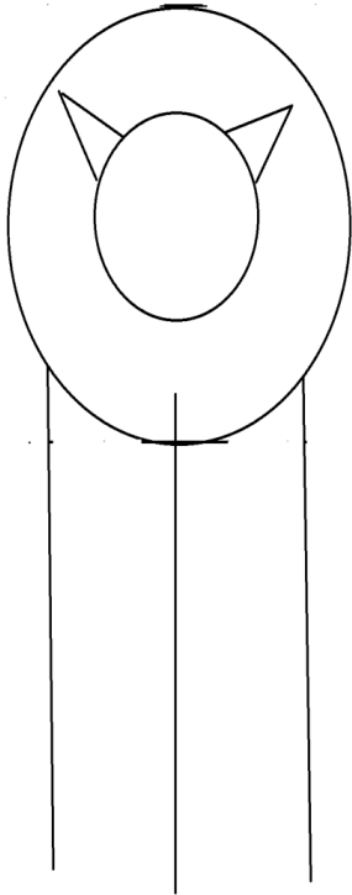

Le poisson

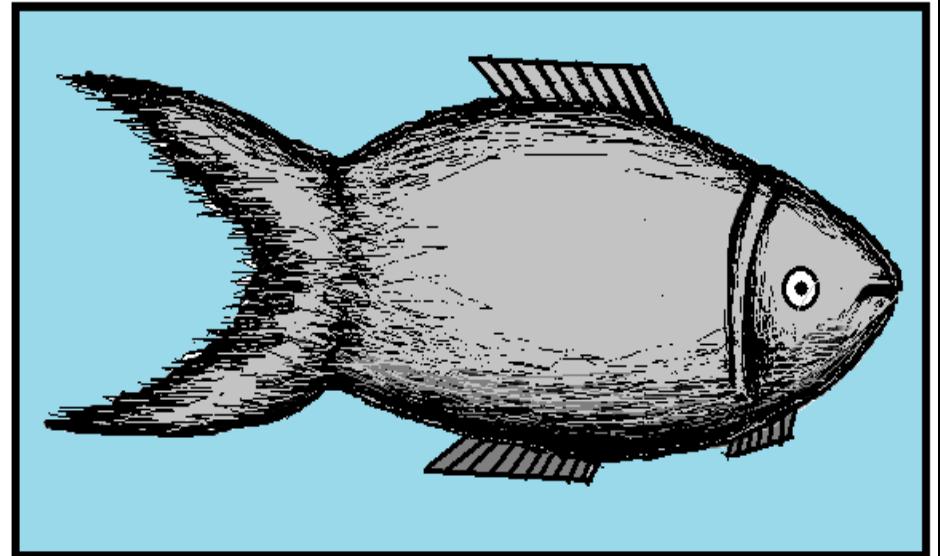
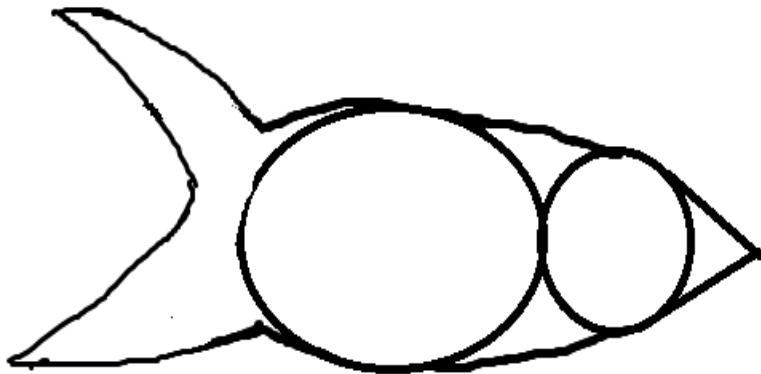
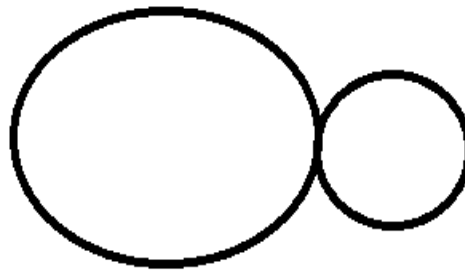
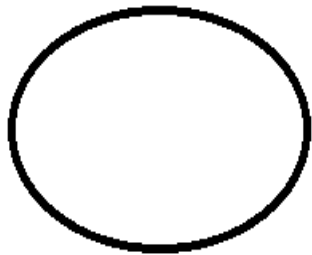

Le parapluie

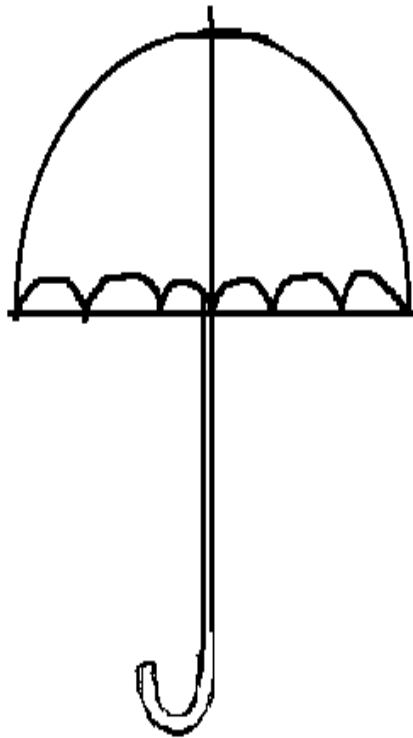
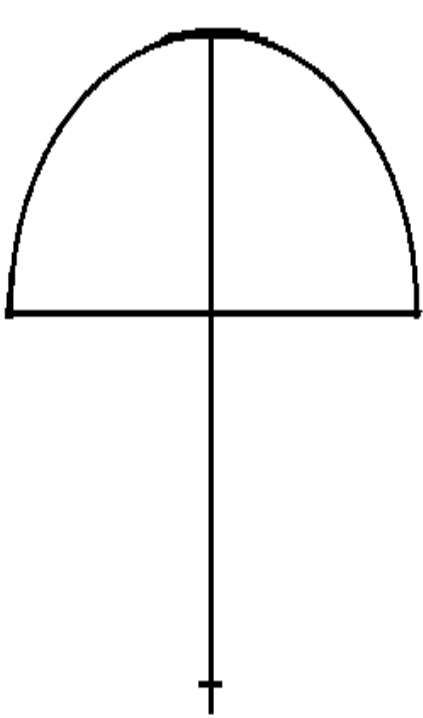

Le plat



La jarre

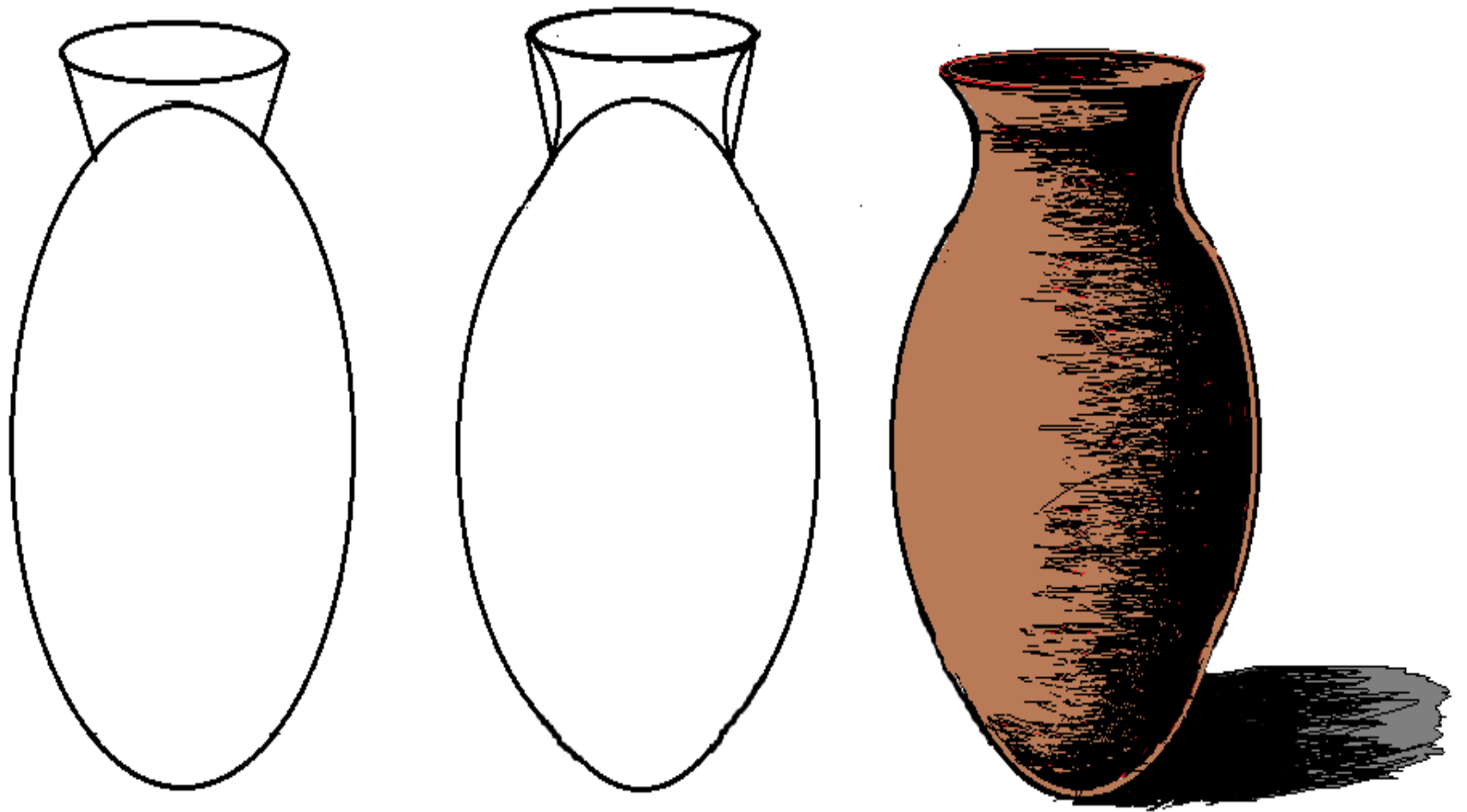

Le chien assis

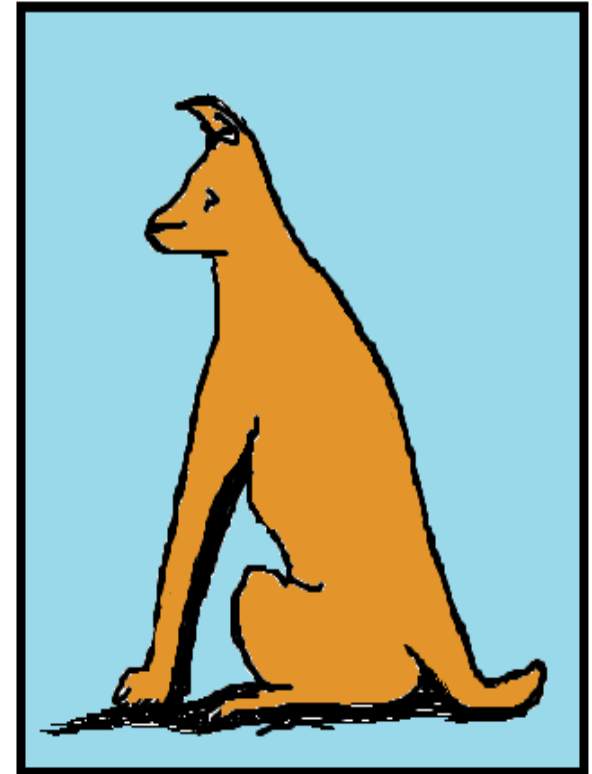
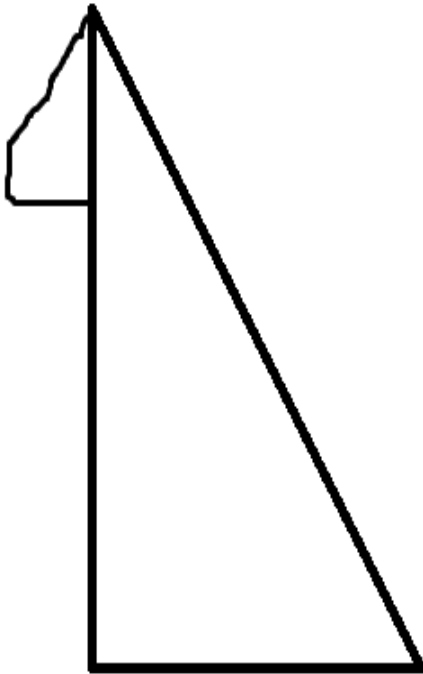

Le mouton

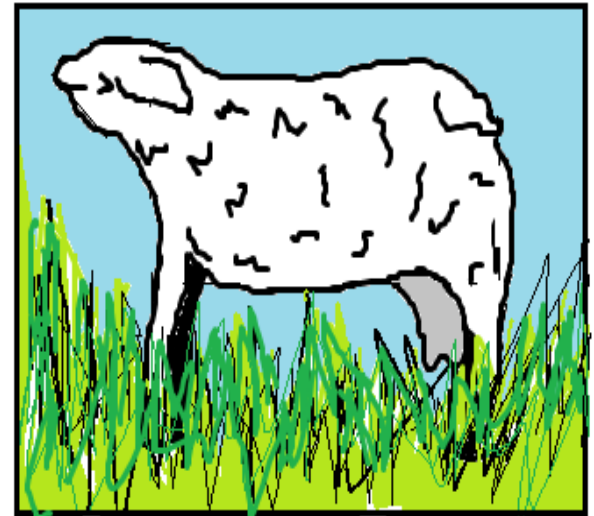
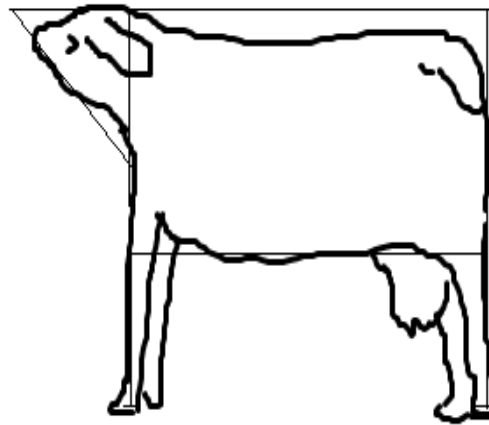
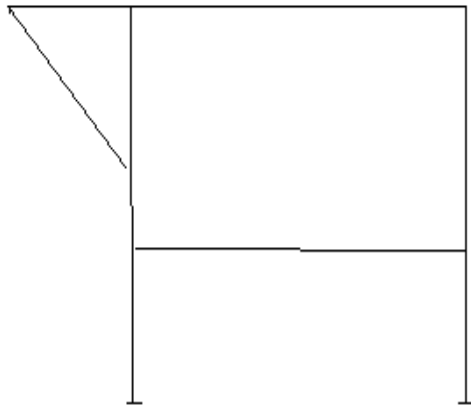

Le coq

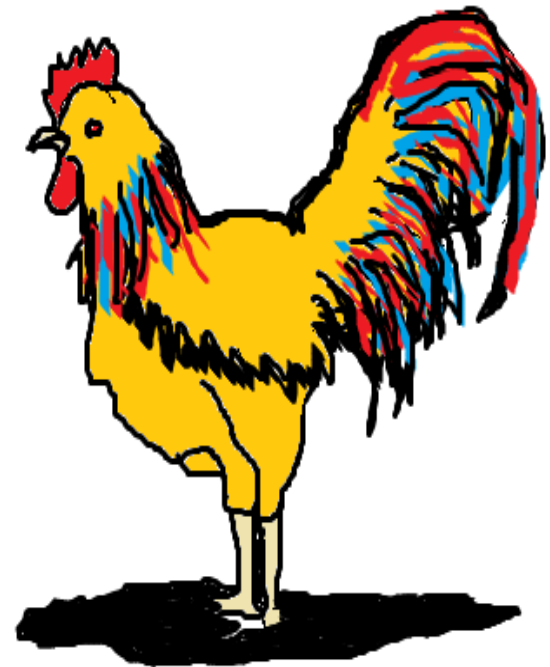
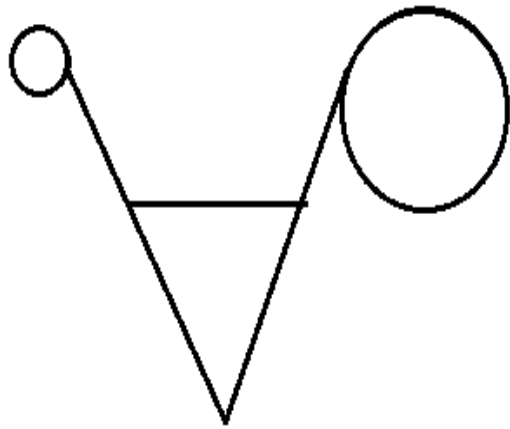

La poule

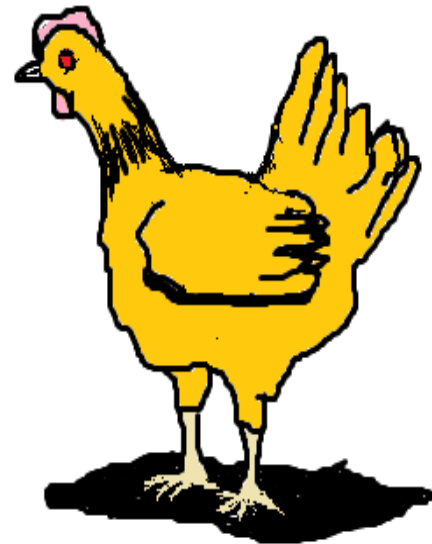
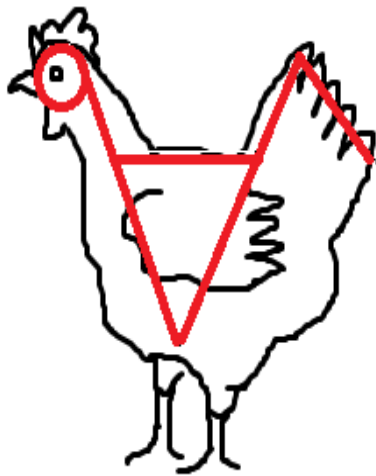
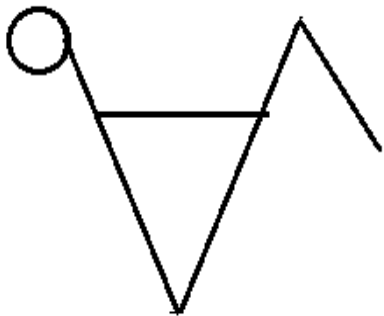

Le poussin

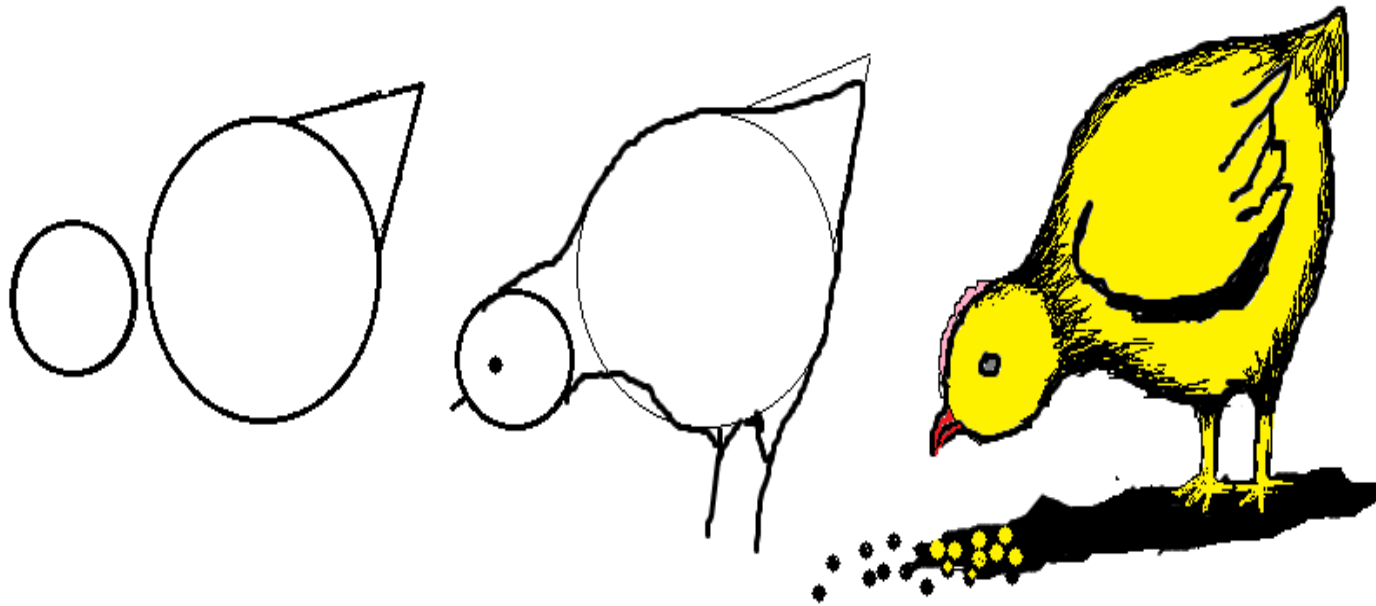

Le chat assis vu de profil gauche

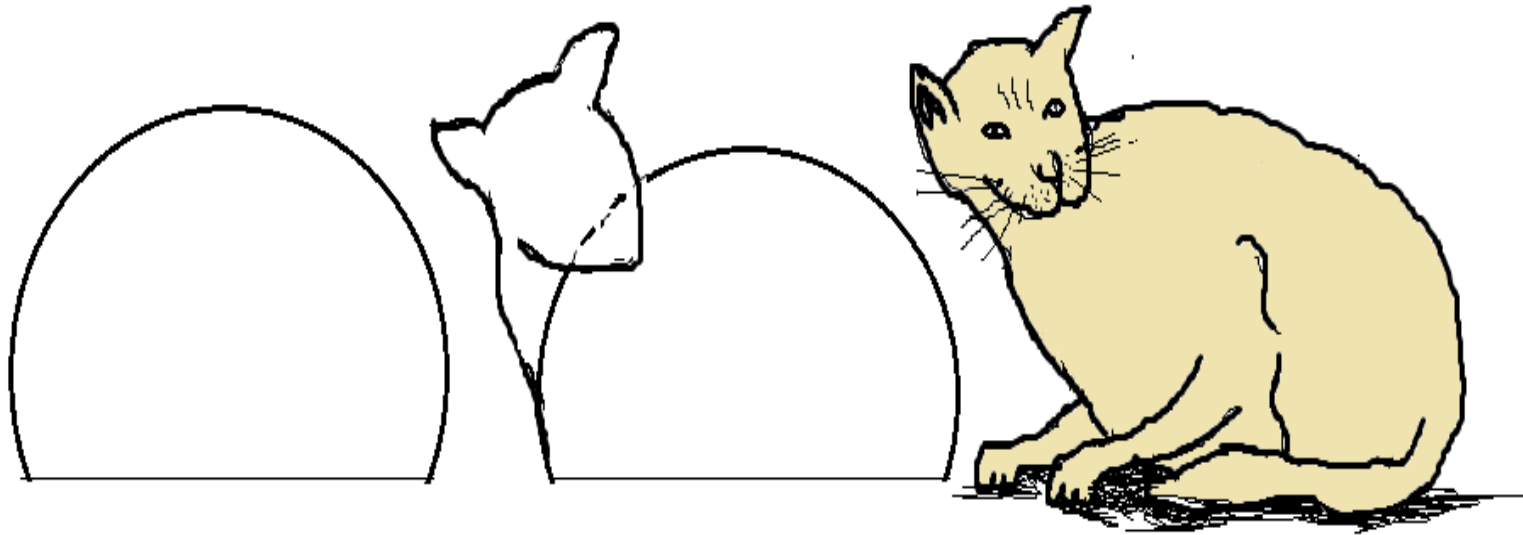

Les arbres

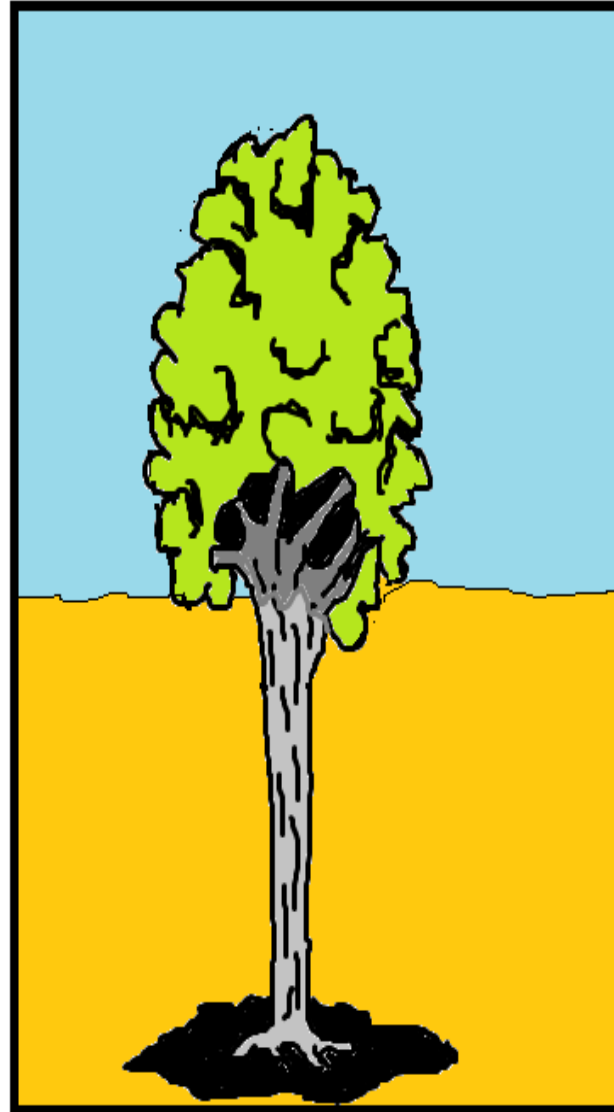
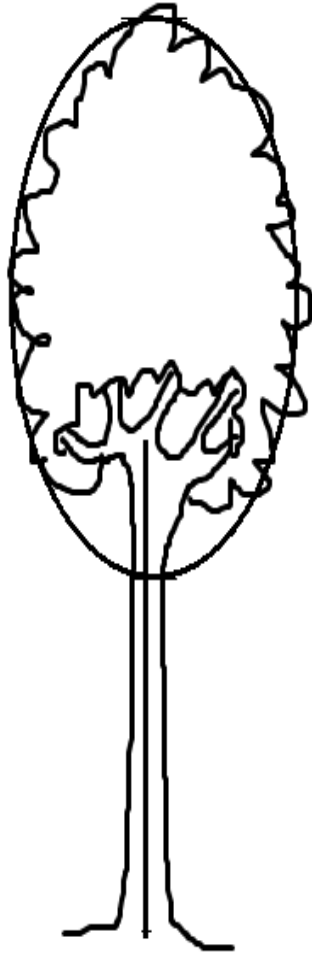
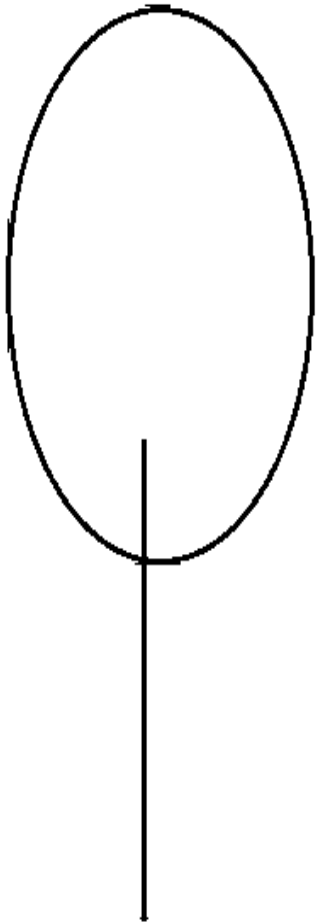

Les arbres

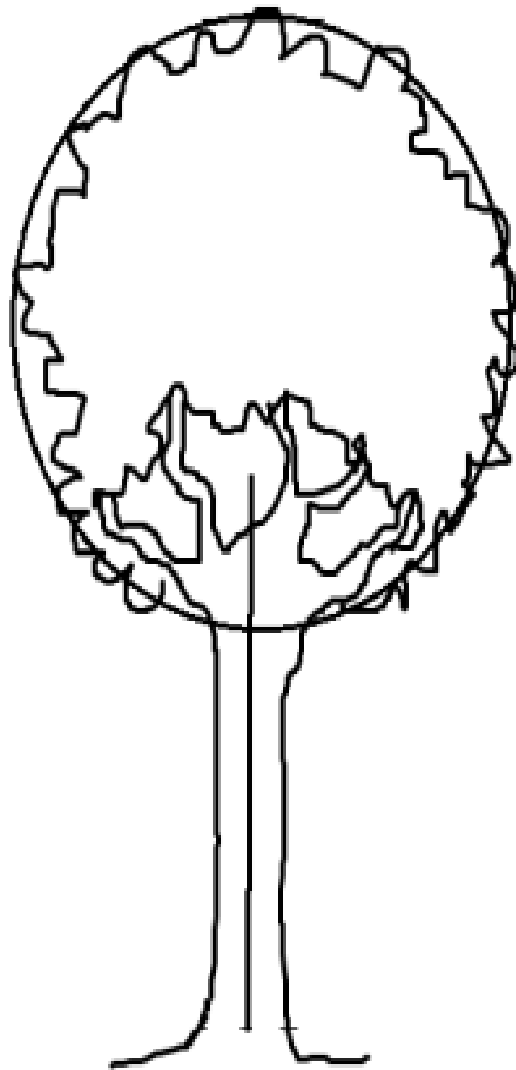
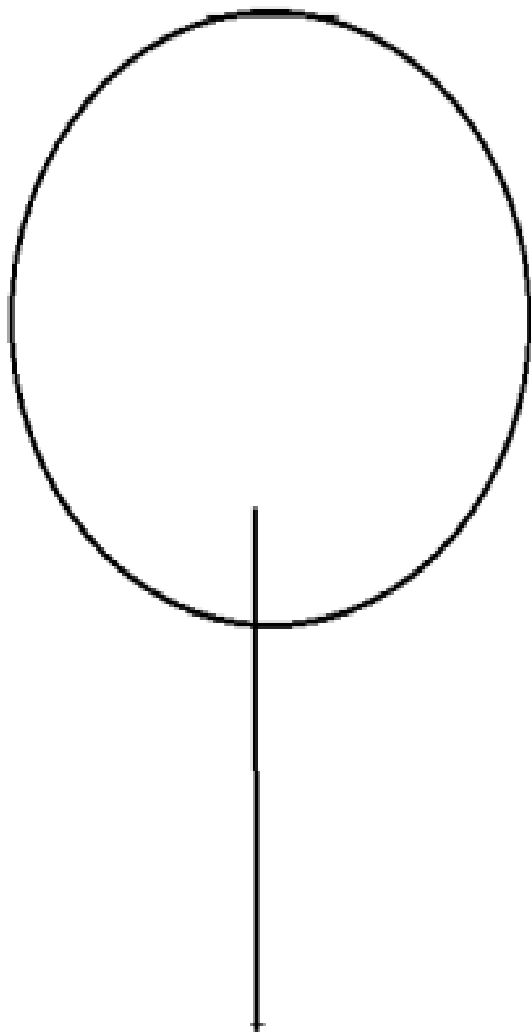

Le cocotier

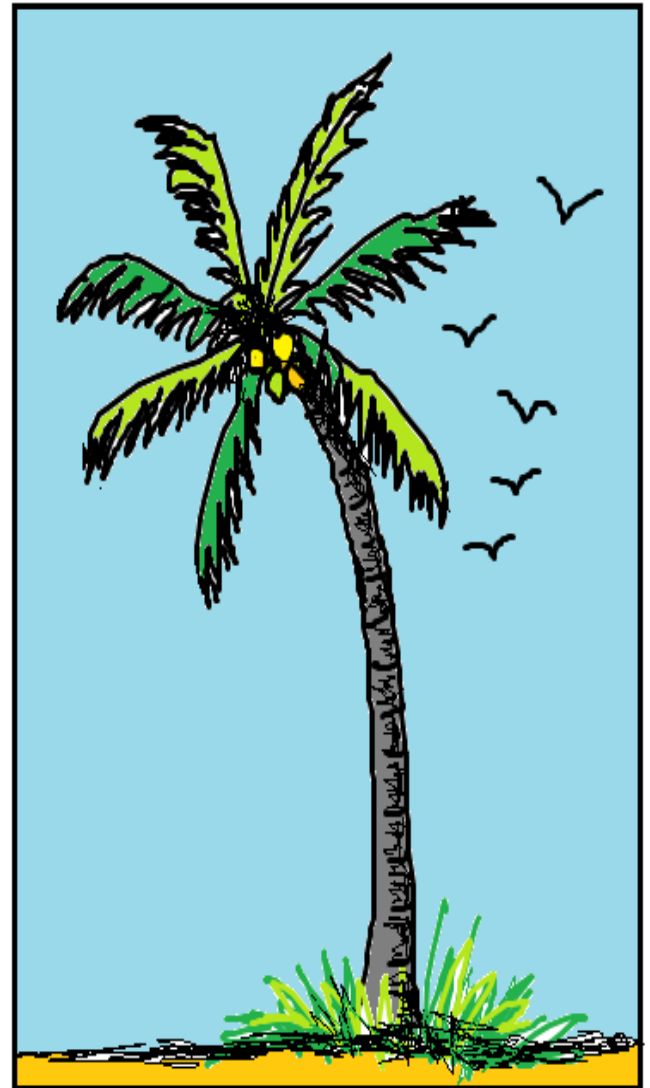
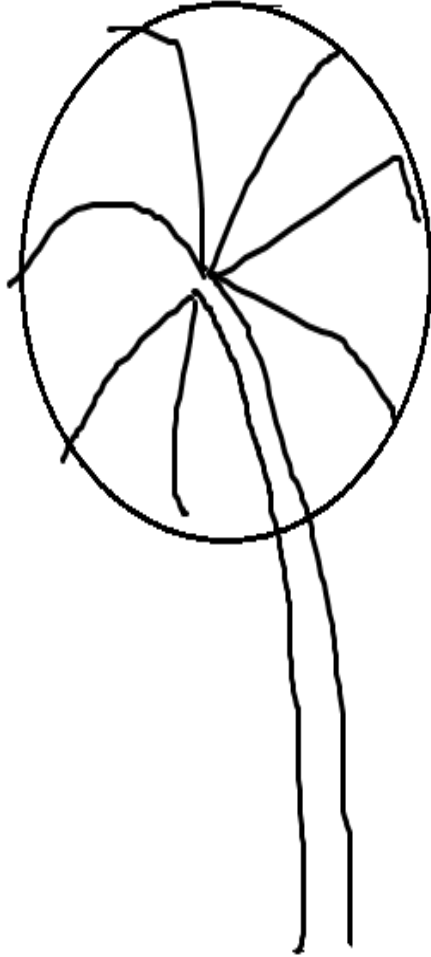
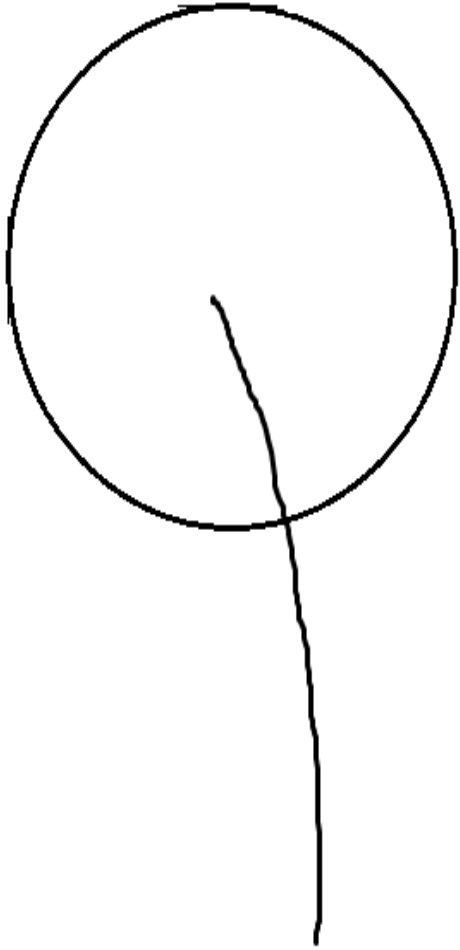

Autres techniques

Le canard

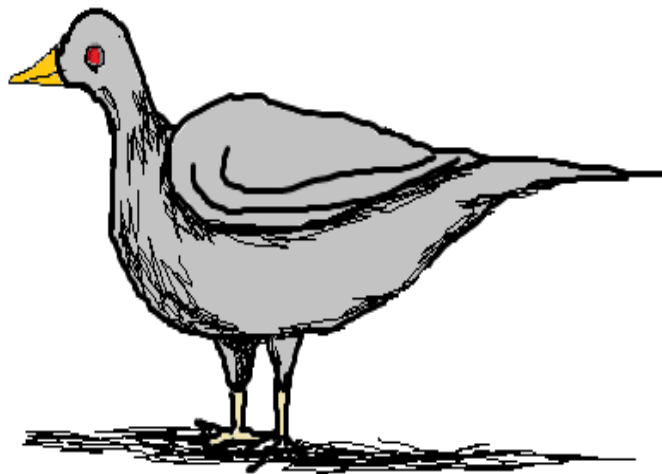
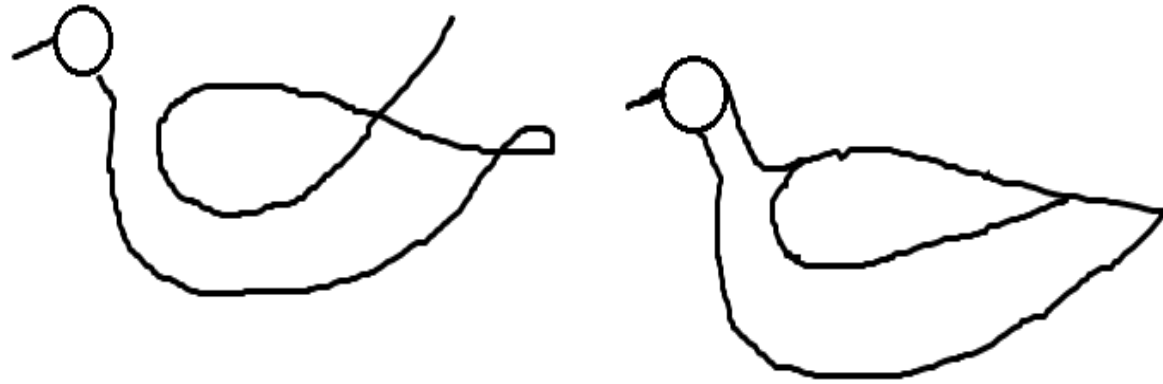

Le bébé assis de face sur une natte

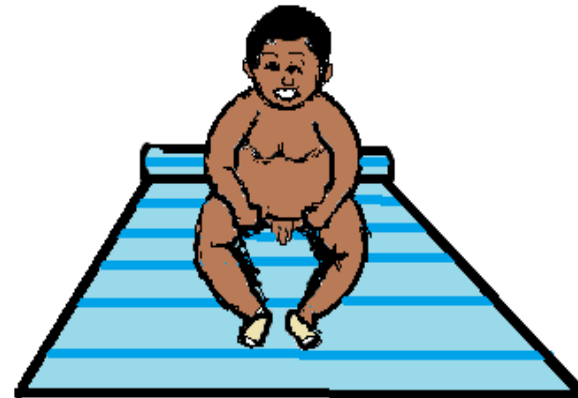

La souris vue de profil gauche

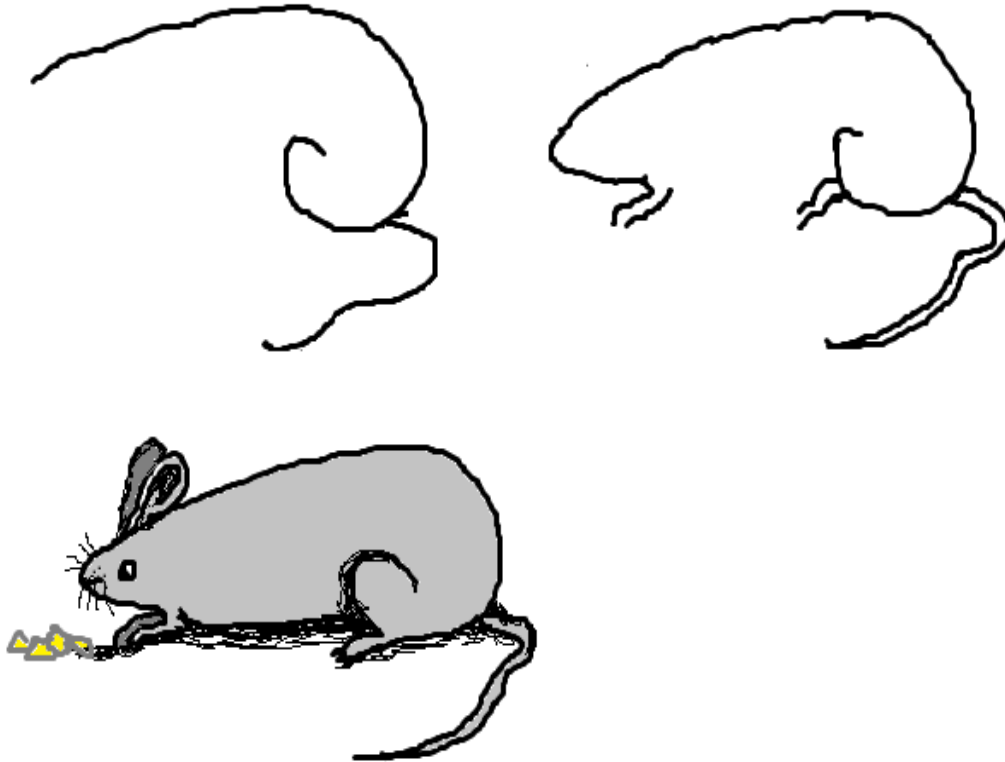

La femme vue de face

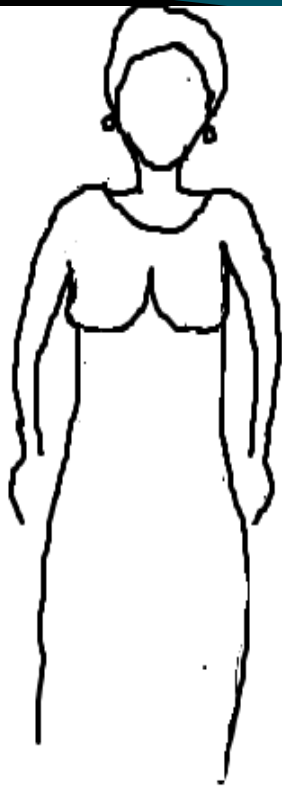

La technique du dessin d'un personnage humain

Le croquis par la charpente osseuse et ses proportions

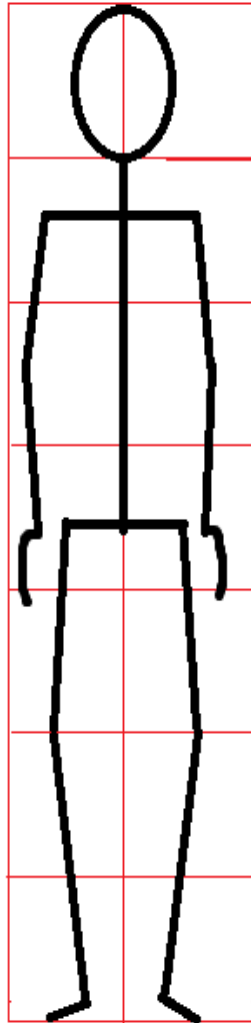

La technique du dessin d'un personnage humain

Le redressement- L'arrangement- La finition

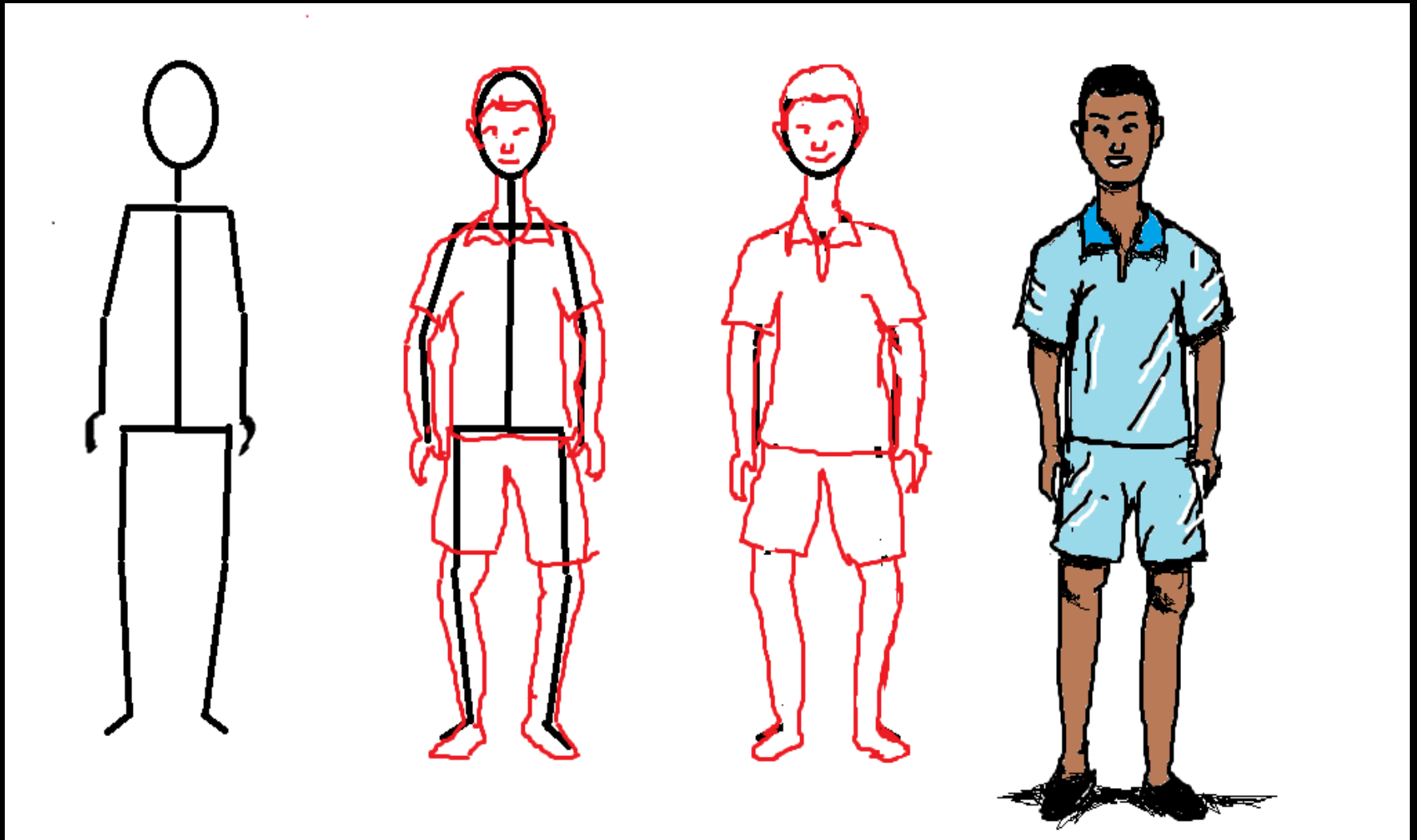

La technique du dessin d'un personnage humain

Le redressement-L'arrangement- La finition



La tête et ses proportions

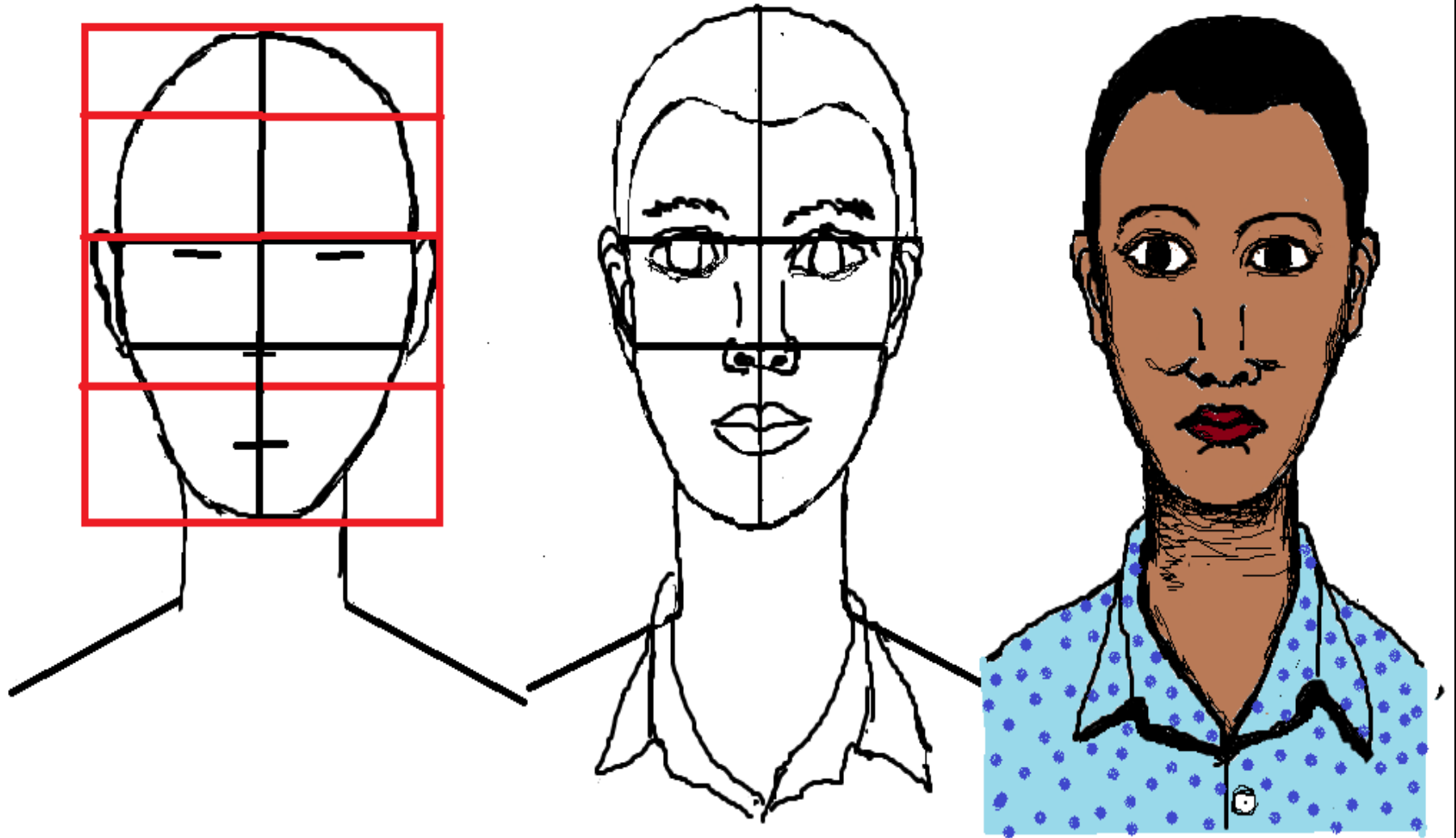

La tête et ses proportions

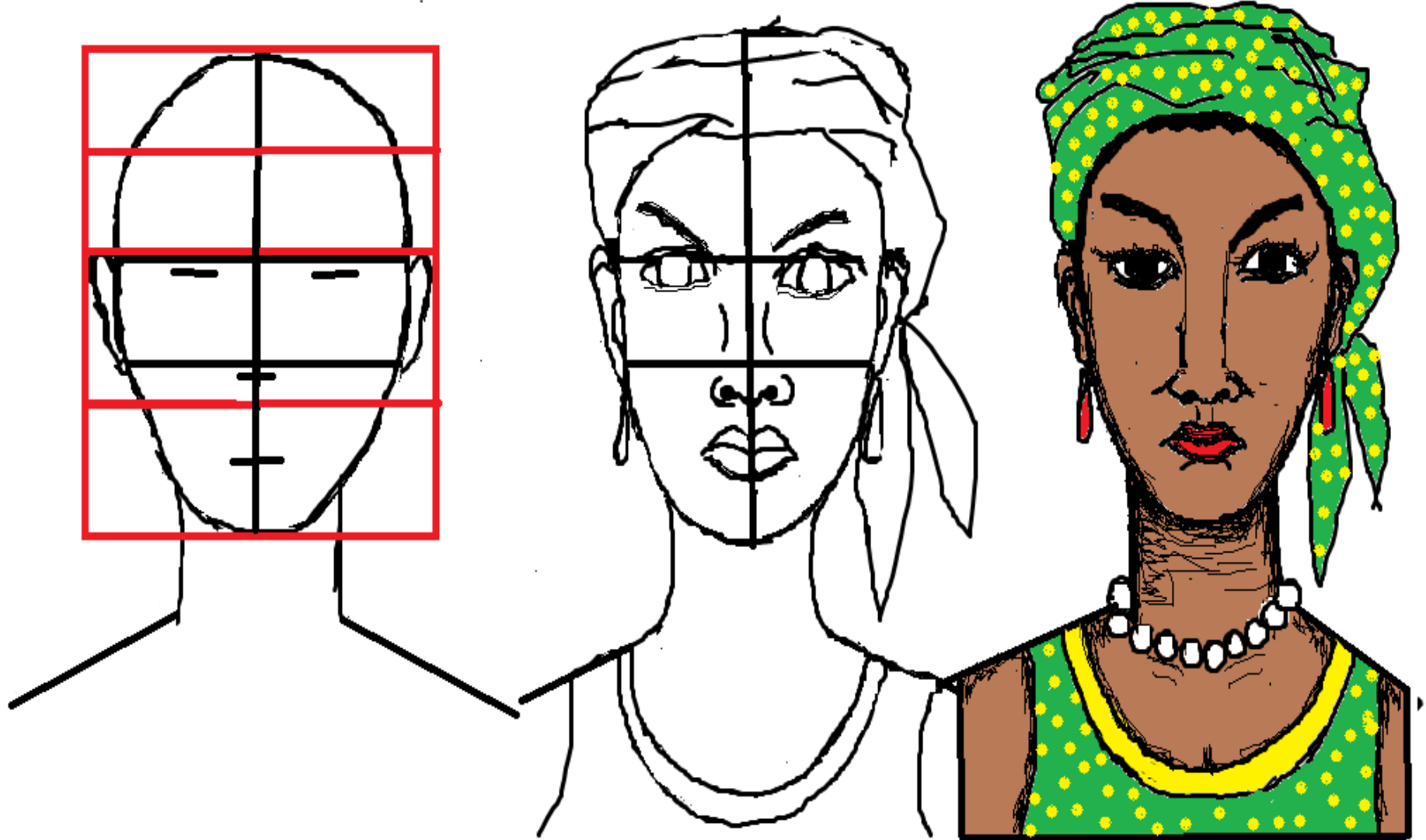

Le croquis

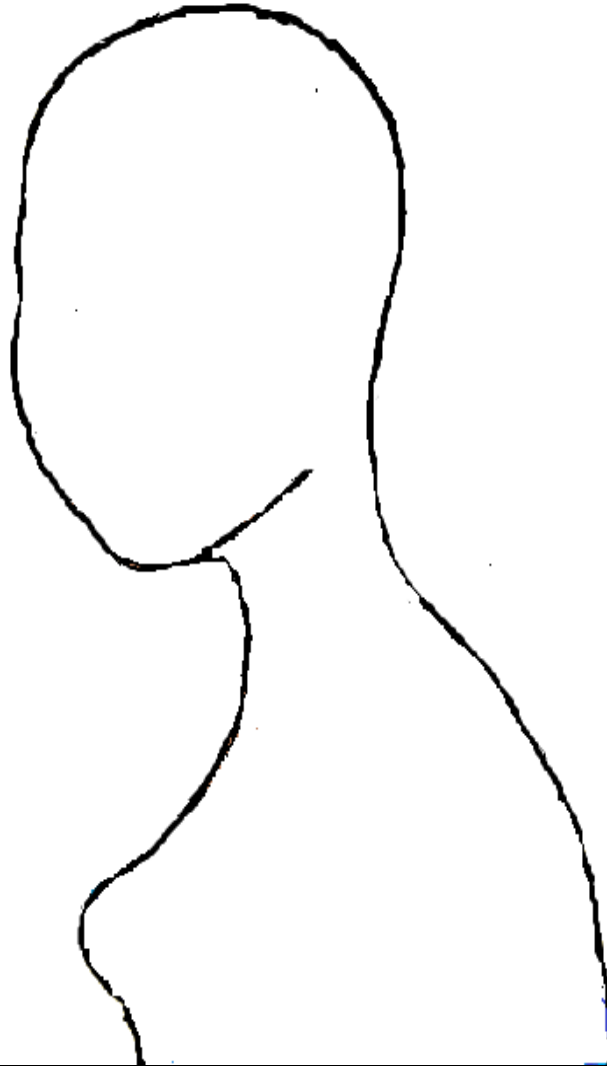

Le croquis (suite)



Le redressement

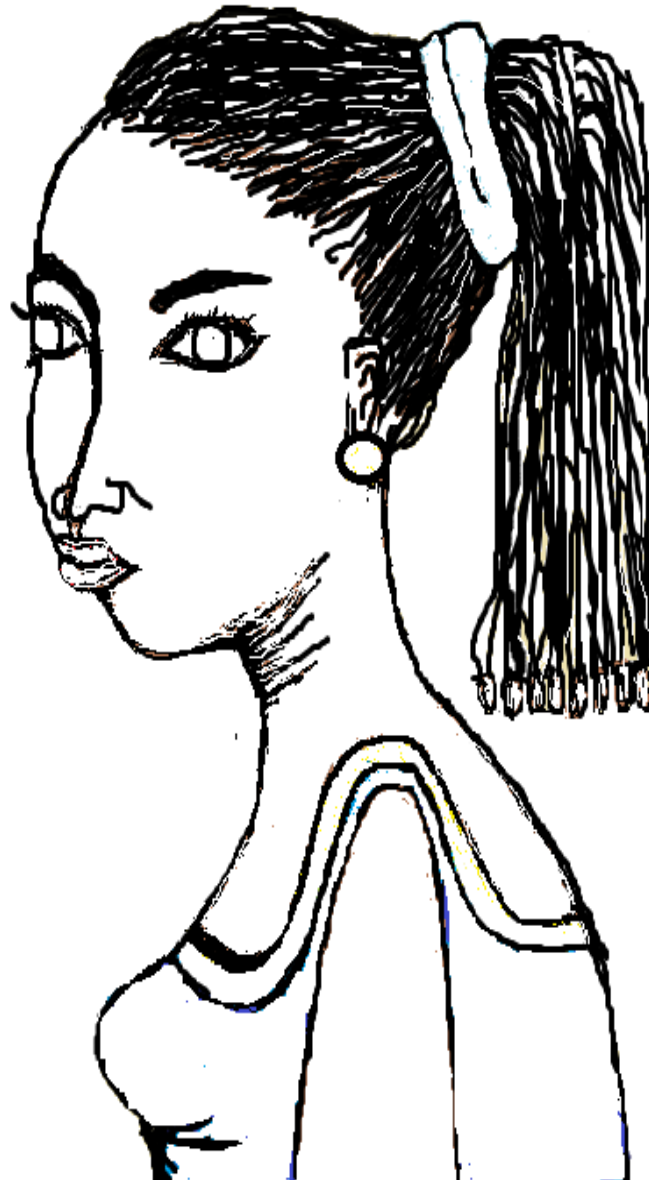

L'arrangement

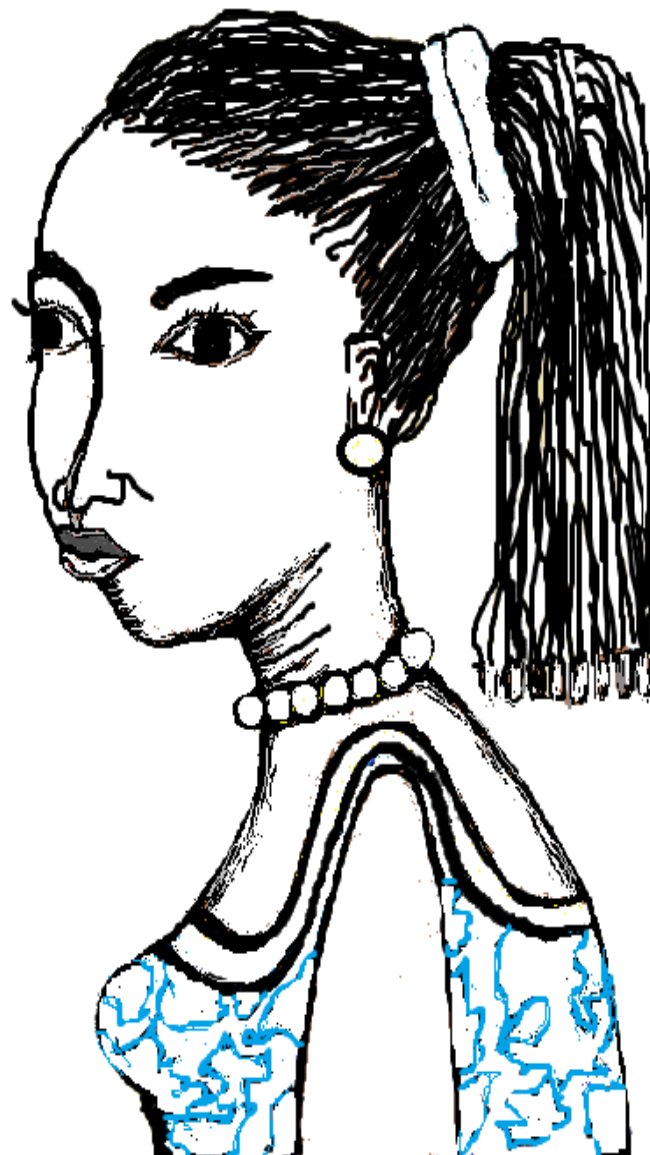

La finition



Les mouvements de la tête

Sens du mouvement de la tête

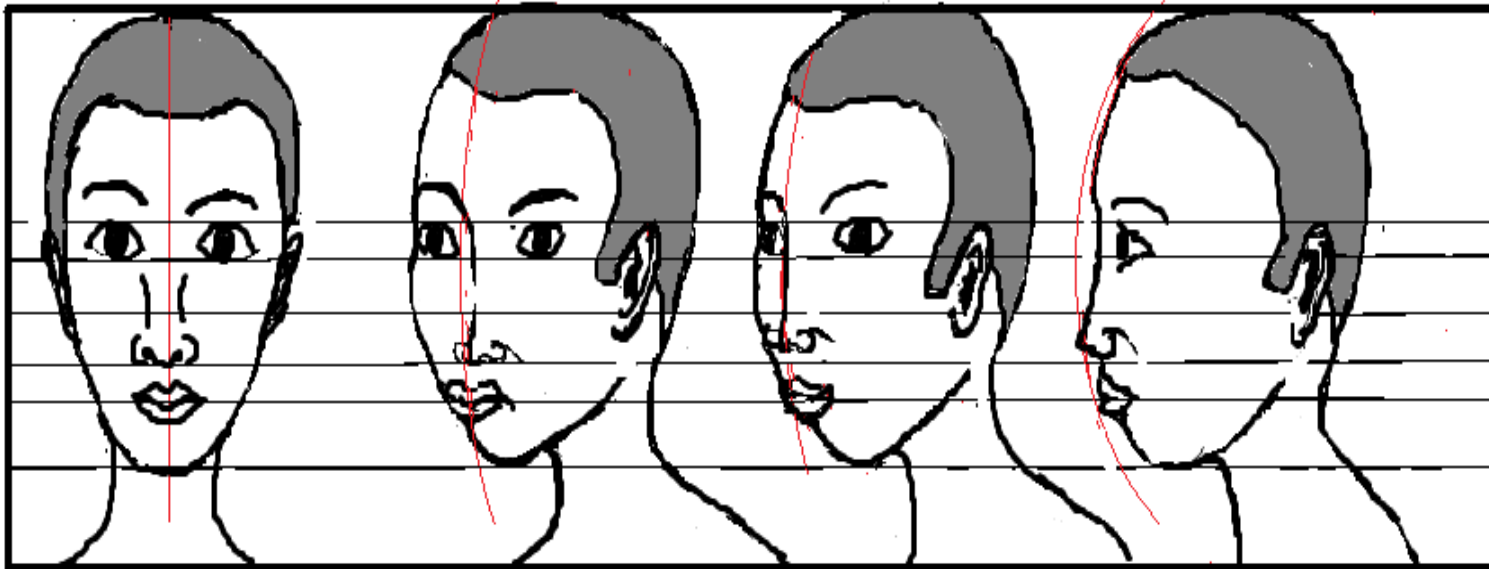

Visage de face

Visage au 3/4

Visage au 3/4

Visage au profil

Le mouvement du corps

Scène de labour

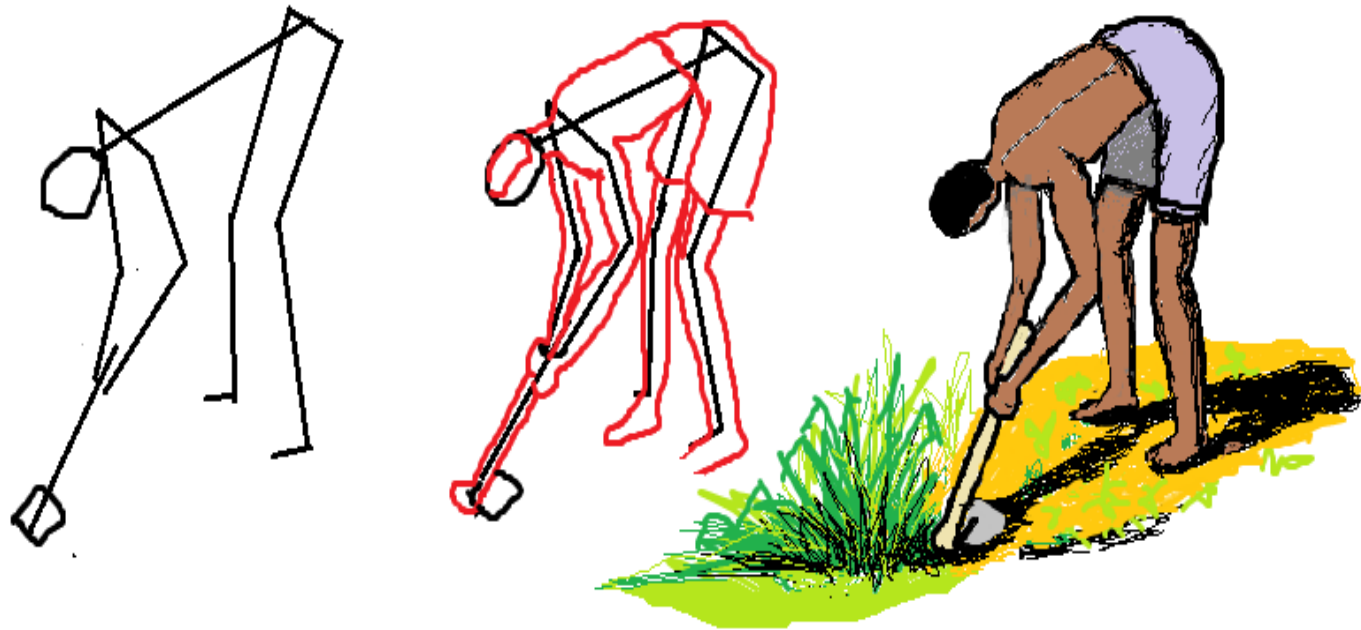

Le mouvement du corps

Scène culinaire



Le coucher

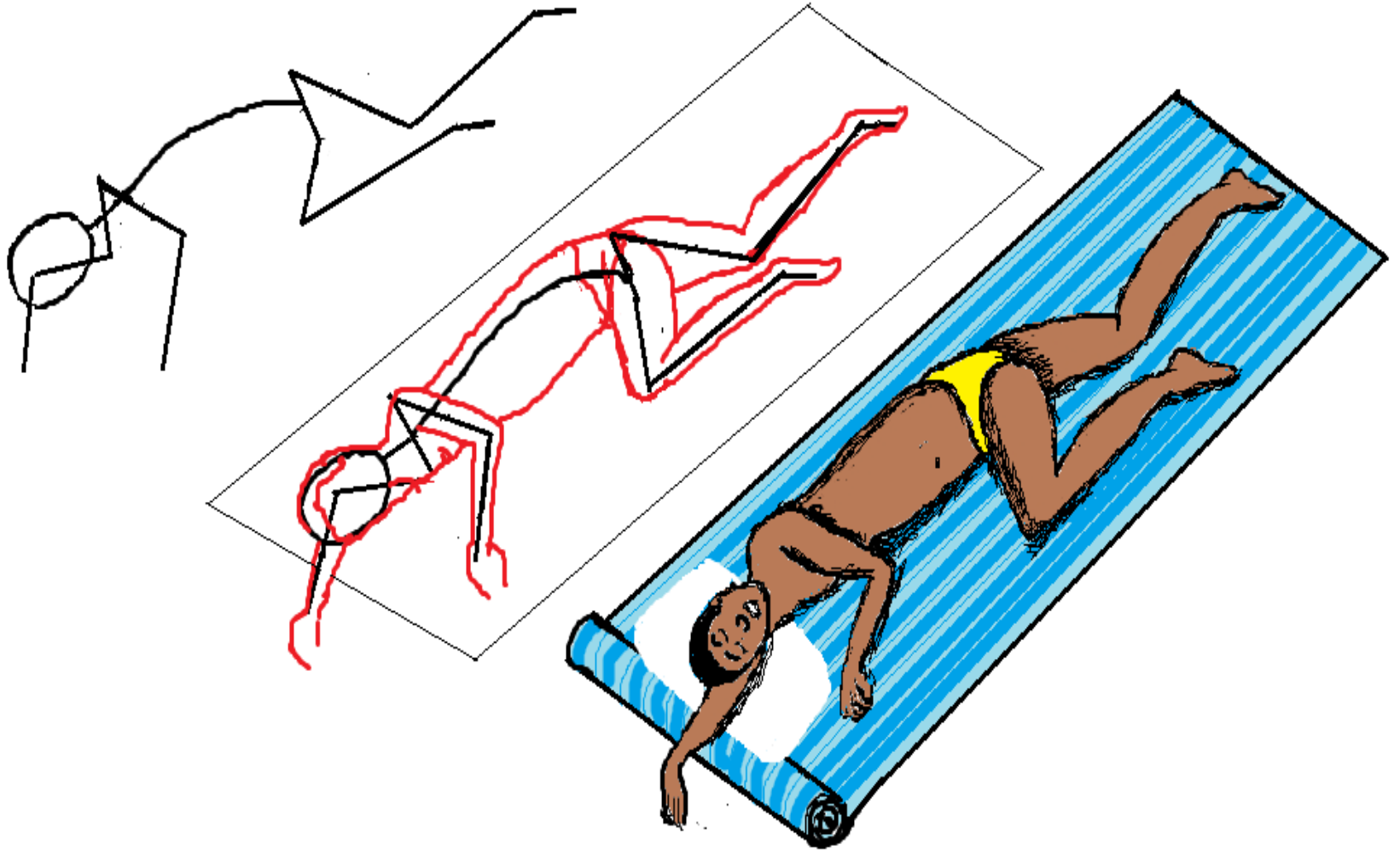

Le mouvement du corps

Croquis : Scène de marché

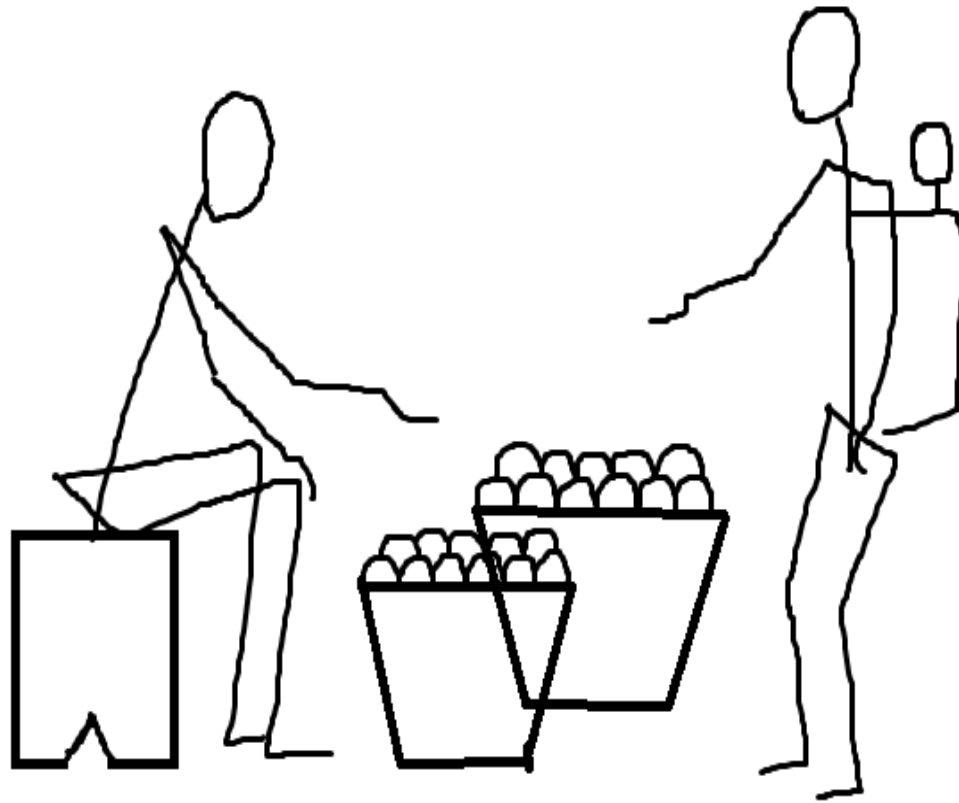

Le mouvement du corps

Redressement et Arrangement



Le mouvement du corps

La Finition



Quelques exemples de composition

Nature morte



Nature morte

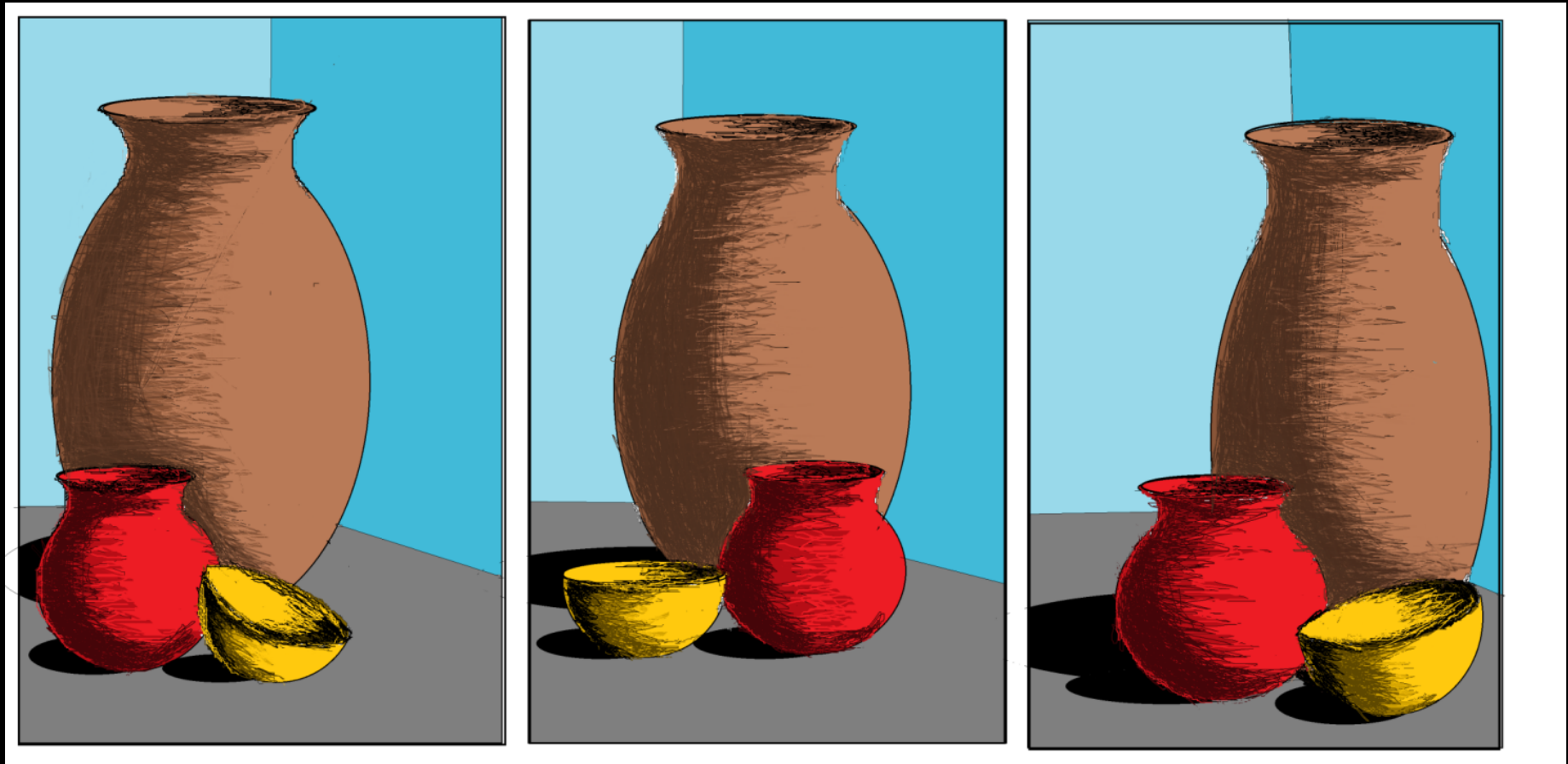

Nature morte



Nature morte

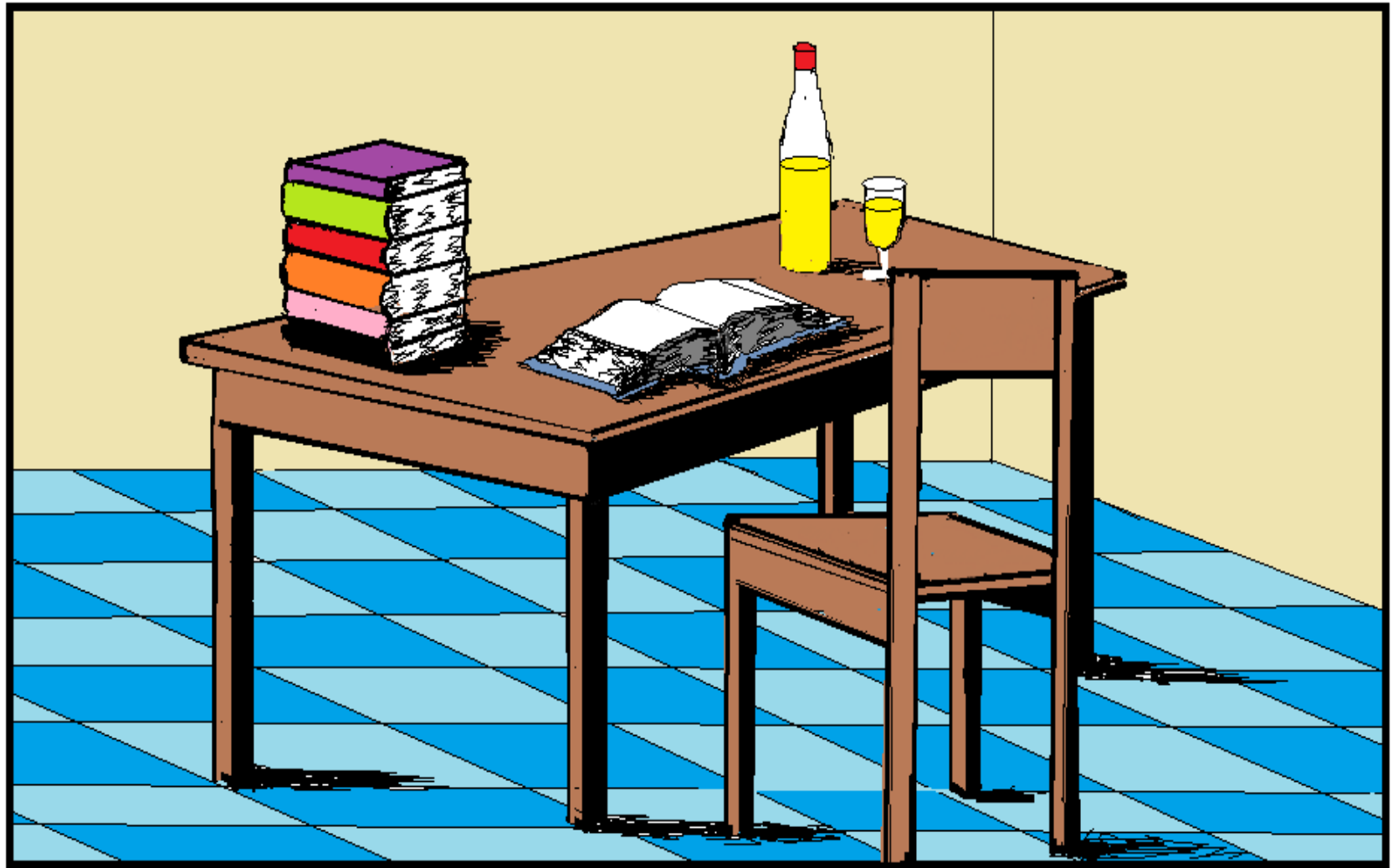

Nature morte



Nature morte

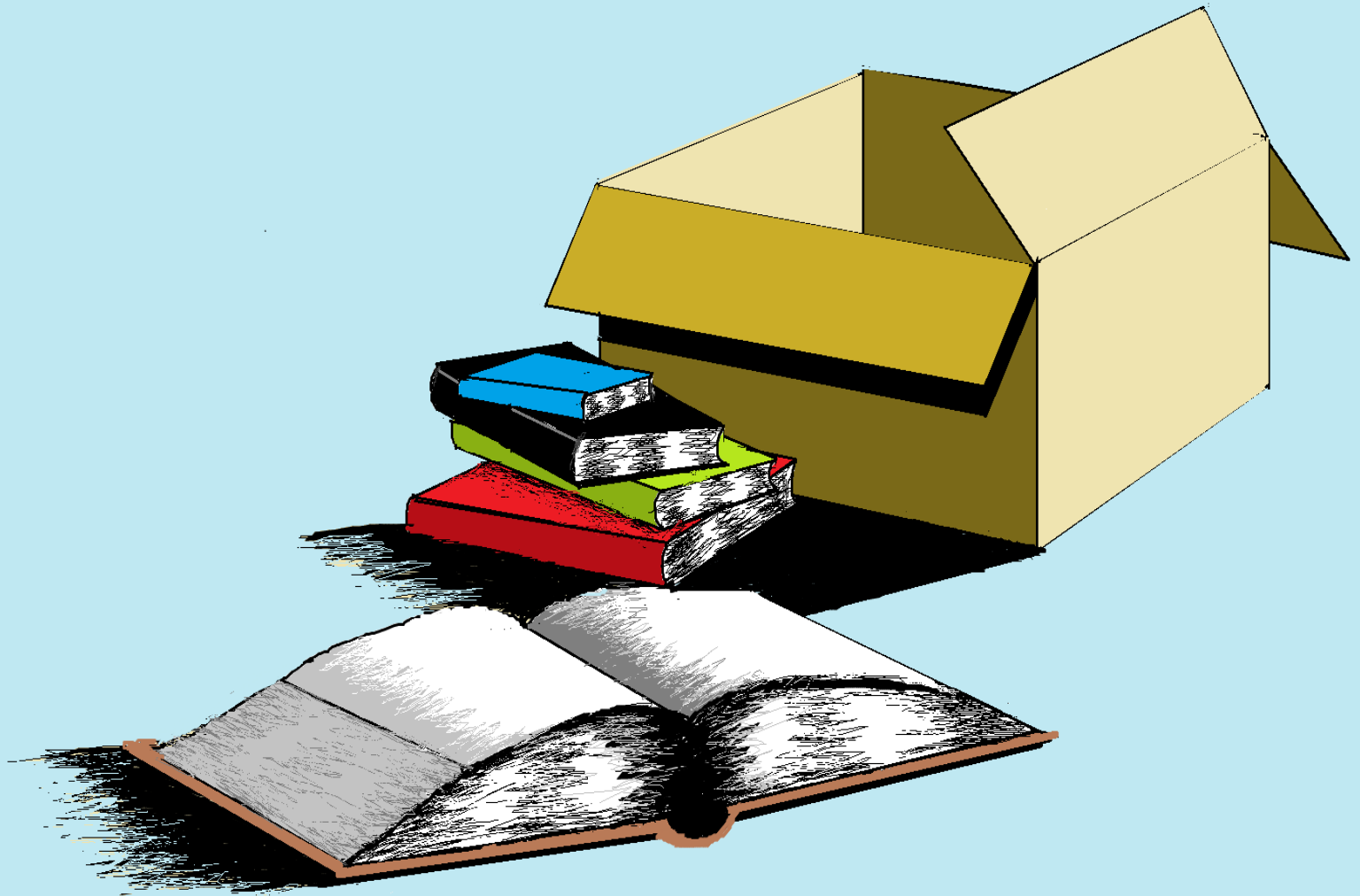

Composition décorative

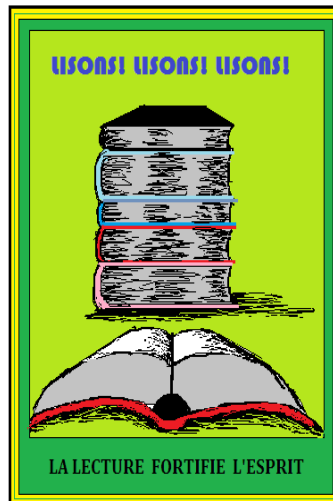
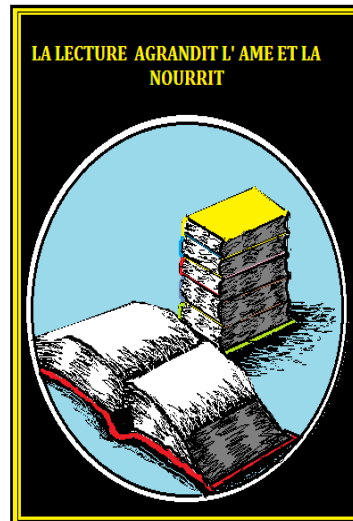
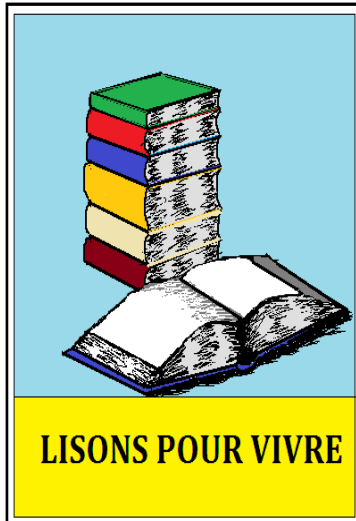

Maquette de tissu (composition décorative)

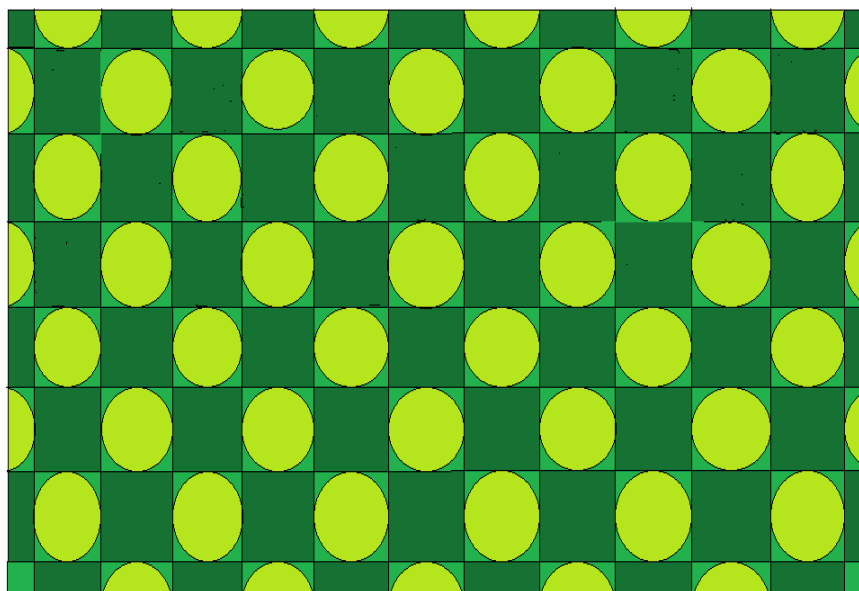

Maquette de tissu (composition décorative)

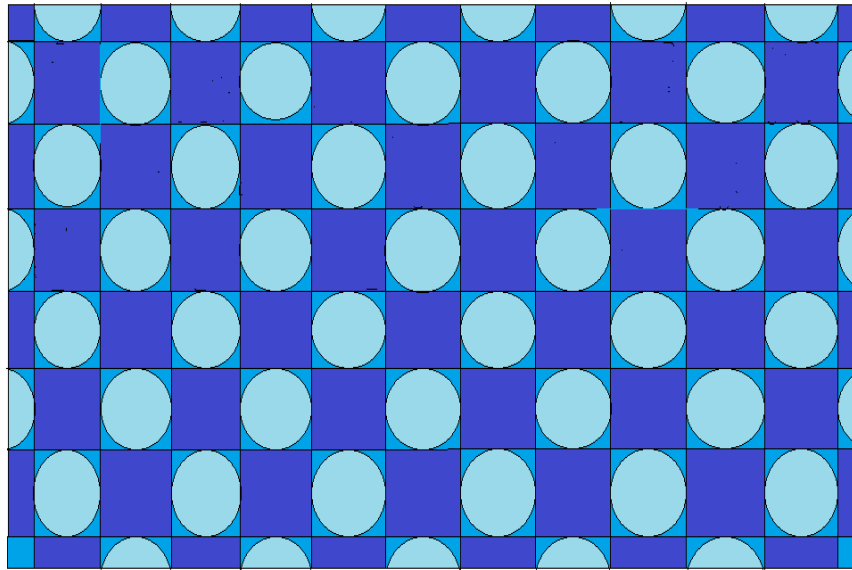

Maquette de tissu (composition décorative)

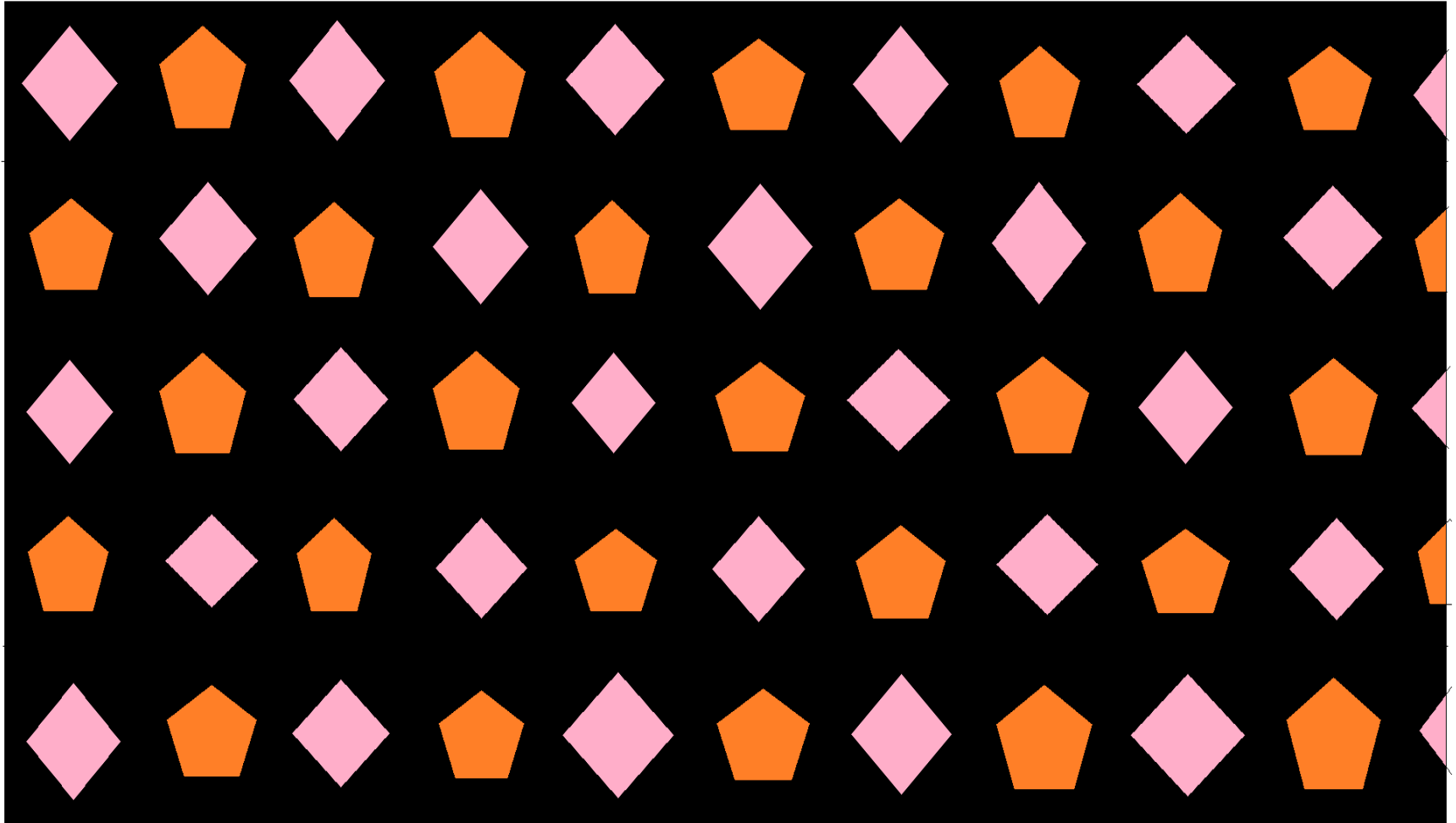

Maquette de tissu (composition décorative)

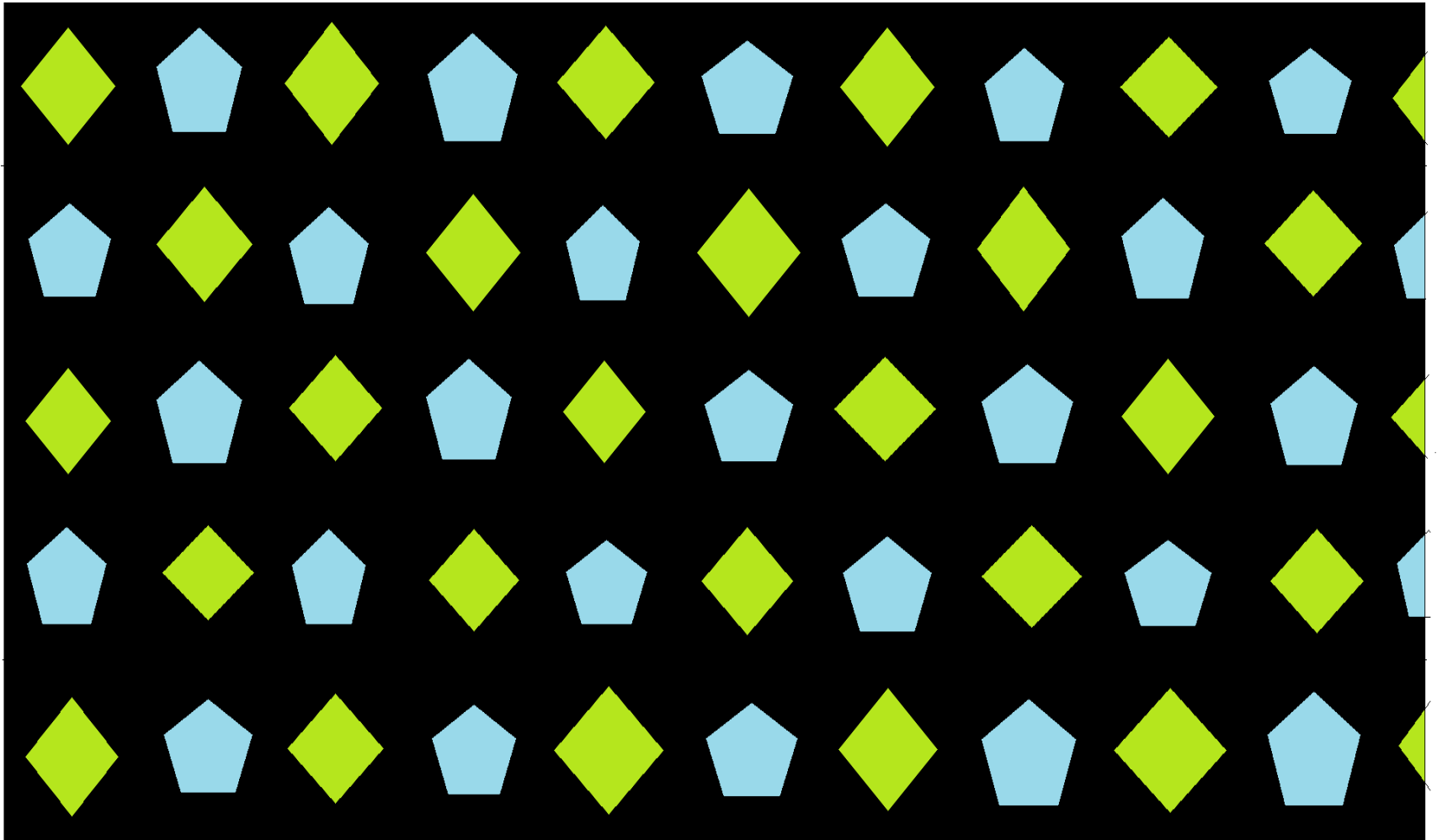

Timbre – poste (composition décorative)

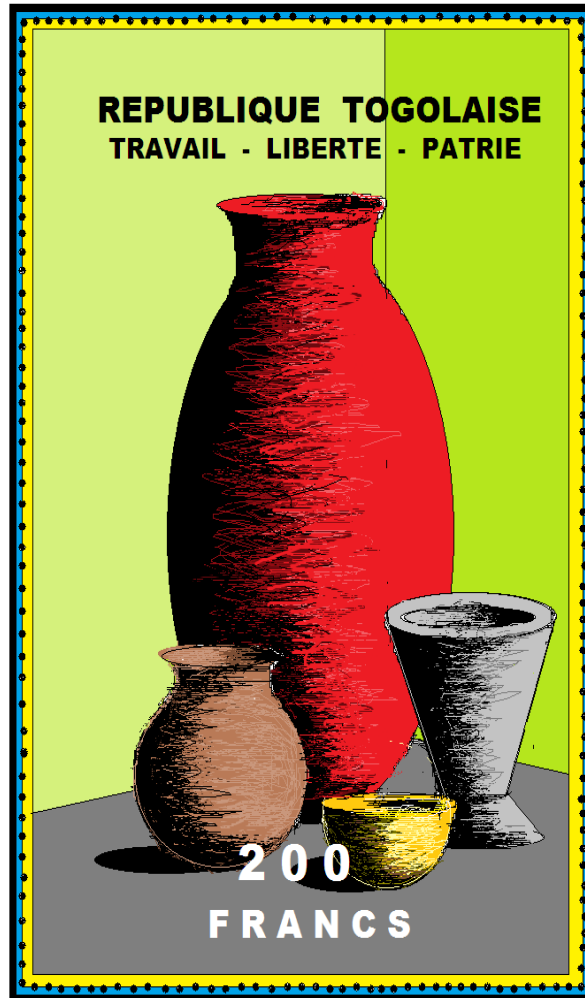

Timbre – poste (composition décorative)

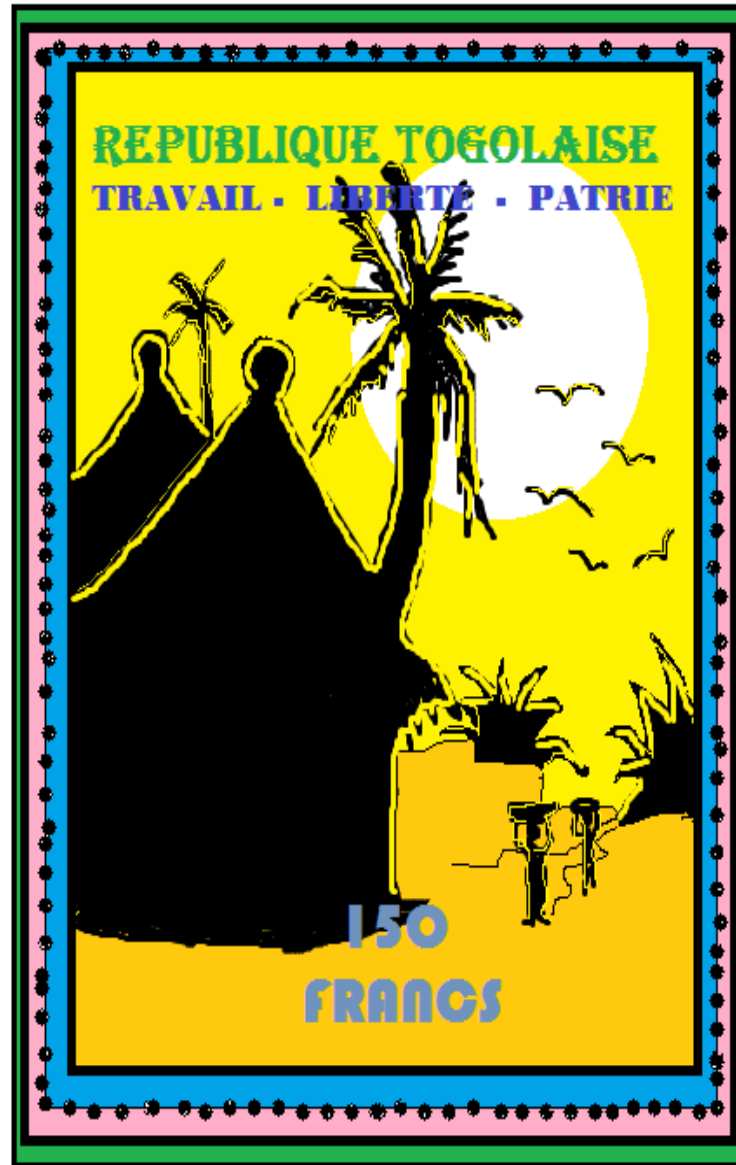

Paysage moyen



Paysage en perspective



Paysage en perspective

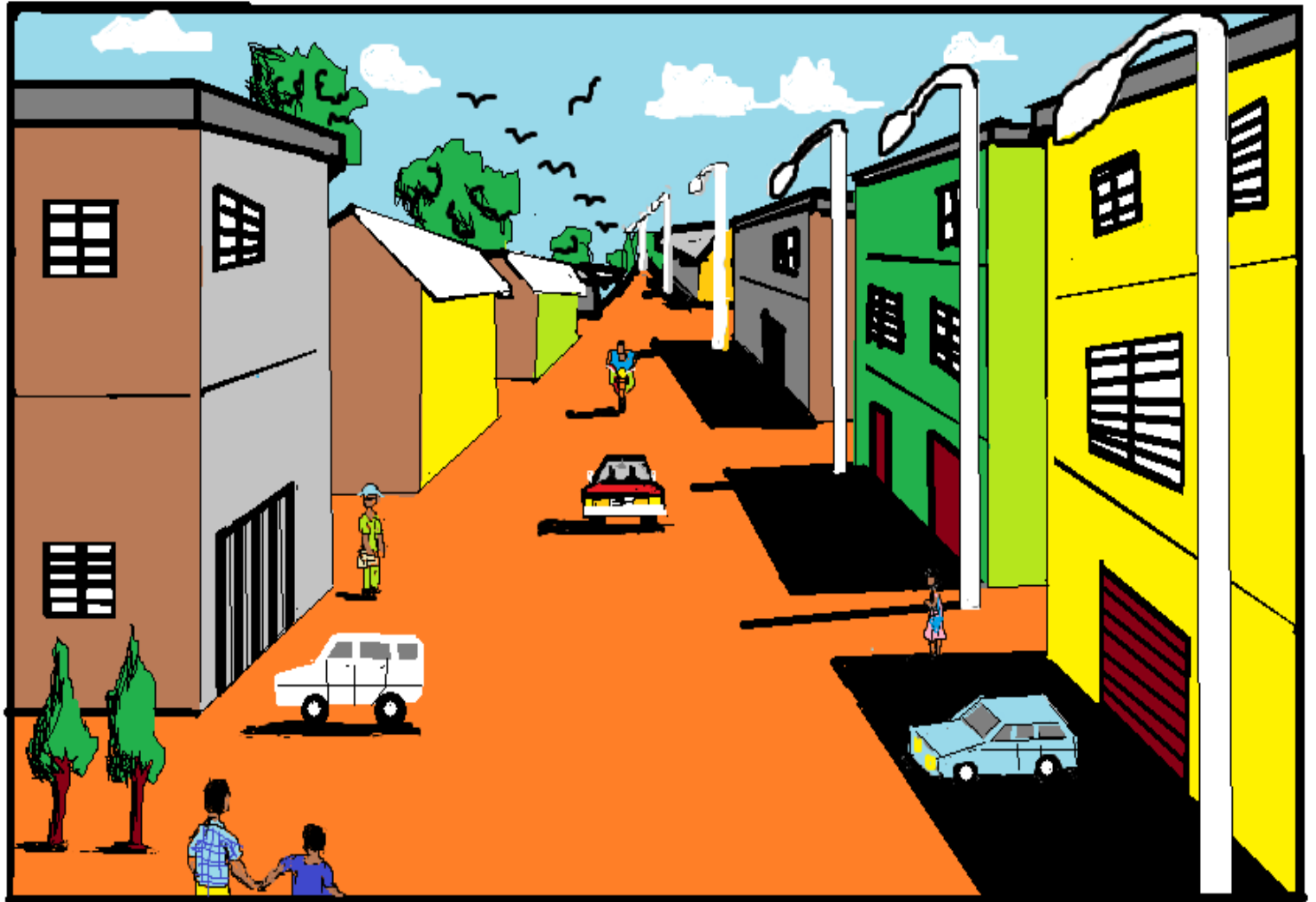

Paysage en perspective



La lessive



**JE
VOUS
REMERCIE**